

 **Çolakoğlu Metalurji**

PRODUCT CATALOGUE

Çolakoğlu



 **Çolakoğlu** Metalurji | PRODUCT CATALOGUE



 **Çolakoğlu** Metalurji

2011-2017 EXPORT LEADER OF HOT ROLLED FLAT PRODUCTS

Sustainability
in
Export



Symbols and Abbreviations Used for Chemical Elements

Sembol	Element
C	Carbon
Mn	Manganese
P	Phosphorus
S	Sulphur
Si	Silicon
Al	Aluminum
Cu	Copper
N	Nitrogen
O	Oxygen
H	Hydrogen
Ca	Calcium
Ti	Titanium
V	Vanadium
Cr	Chromium
Ni	Nickel
Mo	Molybdenum
Nb	Niobium
B	Boron
Sn	Tin
Fe	Iron
Zn	Zinc
Pb	Lead
As	Arsenic
W	Wolfram (Tungsten)
Zr	Zirconium

Symbols and Abbreviations Used for Mechanical Tests

Symbol	Explanation
R_e	Yield strength (N/mm ²)
R_m	Tensile strength (N/mm ²)
R_{p0.2}	Yield strength at high temperature (N/mm ²)
A	Elongation (%)
A₅	Elongation (L ₀ =5,65x√S ₀)
A₅₀	Elongation (L ₀ =50 mm)
A₈₀	Elongation (L ₀ =80 mm)
A₁₀₀	Elongation (L ₀ =100 mm)
A₂₀₀	Elongation (L ₀ =200 mm)
S₀	Cross-sectional area of the specimen (mm ²)
L₀	Original gauge lenght of the specimen (mm)
d	Nominal thickness (mm)
t	Ton
Impact	Impact test
KVc	Impact energy, joule (J)
Temp.	Test temperature (°C)
Bend	Bend test
mrb	Mandrel radius for bending (mm)
mdb	Mandrel diameter for bending (mm)
tran.	Transverse test piece
long.	Longitudinal test piece
HRB	Hardness of Rockwell-B
min.	Minimum
max.	Maximum
=	Equal to
<	Smaller than
≤	Smaller than or equal to
>	Bigger than
≥	Bigger than or equal to
ppm	Parts per million
DWTT	Drop weight tear test
Std.	Standard

CERTIFICATES

CERTIFICATES	
NAME OF CERTIFICATE	INSPECTION TYPE
ISO 14001:2015	Environmental Management System
CE Marking Certificate	Flat Products
Factory Approval for Pressure Purposes	Flat Products
Sustainability Hot Rolled Flat Steel Certificate	Flat Products
Certificate of Conformity of the Production Control	Flat Products
Environmental Product Declaration	Flat Products
TS ISO/IEC 27001: 2013	Information Security Management Systems
TSE Certificate of Conformity to Turkish Standarts	Long Products
G Certificate	Long Products
Germany Product Certificate	Long Products
Nederlands Product Certificate	Long Products
Colombia Product Certificate	Long Products
Costa Rica Product Certificate	Long Products
France Product Certificate	Long Products
Romania Product Certificate	Long Products
Bulgaria Product Certificate	Long Products
Chile Product Certificate	Long Products
Malaysia Product Certificate	Long Products
Israel Product Certificate	Long Products
Austria Product Certificate	Long Products
Sustainability Constructional Steel Certificate	Long Products
BS EN ISO 9001:2015	Long Products
Environmental Product Declaration	Long Products
Product Conformity Certificates	Long Products
ISO 5001:2011	Management Systems of Energy
OHSAS 18001 : 2007	Occupational Health and Safety Management System
Environmental Permit and License Certificate	Production
ISO 9001:2015	Quality Management System Certificate

CERTIFIED BY	COUNTRY	STANDARD / SPECIFICATIONS
CARES	UK	ISO 14001:2015
KIWA	TURKEY	EN 10025-1
BUREAU VERITAS	TURKEY(HPI/VS)	EN 10028-2:2009
CARES	UK	CARES Sustainability Scheme Appendix 06
KIWA	NEDERLANDS	EN 10025. 2004 HRC
BRE ve GReenBookLive	UK	EN 15804:2012 +A1:2013
DENETIK	TURKEY	ISO: 27001: 2013
TSE	TURKEY	TS 708
TSE	TURKEY	TS 708
KIWA	GERMANY	DIN-488
KIWA	NEDERLANDS	NEN-6008
ICONTEC	COLOMBIA	NTC 2289:2015
INTECO	COSTA RICA	INTE 06-09-01, INTE 06-09-02
AFCAB	FRANCE	NFA 35-080-1
ICECON	ROMANIA	SR 438-1:2012, ST 009:2011
BULGAR KONTROLA	BULGARIA	BDS 9252:2007
INN	CHILE	NCH 204
SIRIM	MALAYSIA	MS 146:2014
SII	ISRAEL	Preliminary Tests Agreement
ACRS	AUSTRIA	AS/NZS4671
CARES	UK	CARES Sustainability Scheme Appendix 01
CARES	UK	BS EN ISO 9001:2015 BS 4449:2005
BRE ve GReenBookLive	UK	EN 15804:2012 +A1:2013
CARES	UK	ISO 9001
VERICERT	TURKEY	ISO 5001:2011
CARES	UK	OHSAS 18001:2007
Ministry of Environment and Urban Planning	TURKEY	National Regulations
BUREAU VERITAS	TURKEY	ISO 9001:2015

INDEX

FLAT STEEL PRODUCT QUALITIES & USING AREAS				
Using Areas of Steel Qualities	Standard	Standard Quality	Colakoglu Quality ID	Page No.
HOT ROLLED COILS FOR COLD ROLLING AND GALVANIZING	DIN 1614-Part 1	St 22	20122	26
		St 22-low Cu	25122	
		RRSt 23	20123	
		St 24	20124	
		RRSt 23-with B	30623	
		St 24-with B	30624	
HOT ROLLED LOW CARBON STEELS FOR COLD FORMING	EN 10111-2008	DD11-low Cu	30111	27
		DD12	30112	
		DD13	30113	
		DD11	35111	
		DD11-High strenght	34111	
		DD12 with B	30612	
HOT ROLLED STEELS SUITABLE FOR COLD ROLLING AND GALVANISING	SAE J403-2009	SAE 1006	21006	28
		SAE 1006-low Mn	21106	
		SAE 1008	21008	
		SAE 1010	21010	
		SAE 1010-high Mn	21110	
		SAE 1012-high Mn	21112	
		SAE 1006-B	21606	
SAE 1018 low Mn	21118			
UNALLOYED GENERAL STRUCTURAL STEEL SUITABLE	ASTM A 36-2005	A36	56036	29
UNALLOYED GENERAL STRUCTURAL STEEL SUITABLE FOR GALVANIZING	ASTM A 36-2005	A 36-low Si	56436	29
UNALLOYED PIPE AND PROFILE STEELS	ASTM A53-2006	Grade A	56053	30
UNALLOYED PIPE AND PROFILE STEELS SUITABLE FOR GALVANIZING	ASTM A53-2006	Grade A-low Si	56453	30
PIPE AND PROFILE STEELS	ASTM A53-2006	Grade B-with Si	56052	31
UNALLOYED PIPE AND PROFILE STEELS SUITABLE FOR GALVANIZING	ASTM A53-2006	Grade B-low Si	56452	31
UNALLOYED GENERAL STRUCTURAL STEEL	ASTM A 283-2003	Grade C	56380	32
UNALLOYED PIPE AND PROFILE STEELS SUITABLE FOR GALVANIZING	ASTM A 500-2007	Grade B	56542	32
		Grade C	56546	
CARBON STEEL SUITABLE FOR USING WITH A PRESSURE AT MIDDLE AND HIGH TEMPERATURES	ASTM A 516-2010	ASTM A 516 Grade 60	56660	33

FLAT STEEL PRODUCT QUALITIES & USING AREAS				
Using Areas of Steel Qualities	Standard	Standard Quality	Çolakoğlu Quality ID	Page No.
HIGH STRENGTH LOW ALLOY STRUCTURAL STEELS	ASTM A572 -2007	Grade 50 Type 1	56350	33
		Grade 50 Type 2	56550	
		Grade 55 Type 1	56355	
		Grade 55 Type 2	56555	
		Grade 60 Type 1	56560	
		Grade 65 Type 1	56565	
MICROALLOYED HIGH STRENGTH STEEL RESISTANT TO ATMOSPHERE CORROSION	ASTM A 606	Type 2	55340	34
STRUCTURAL STEELS SUITABLE FOR COLD FORMING AND BENDING	ASTM A 1011 A 1011M-2007	CS Type B	56340	35
		SS Grade 33	56360	
		SS 36 Type 1	56365	
		SS 36 Type 2	56400	
		SS Grade 40	56275	
		SS Grade 50-low Si	56454	
		SS Grade 50	56450	
		SS Grade 55-low Si	56484	
MICROALLOYED STRUCTURAL STEELS SUITABLE FOR COLD FORMING AND BENDING	ASTM A 1011 A 1011M-07	HSLAS Grade 45 Class 2	56245	36
		HSLAS Grade 50 Class 1-low Si	56150	
		HSLAS Grade 50 Class 1	56151	
		HSLAS Grade 50 Class 2	56250	
		HSLAS Grade 55 Class 1-low Si	56155	
		HSLAS Grade 55 Class 1	56156	
		HSLAS Grade 55 Class 2	56255	
		HSLAS Grade 60 Class 1	56160	
		HSLAS Grade 60 Class 2	56260	
		HSLAS Grade 70 Class 2	56270	
		HSLAS-F Grade 80	56080	
		HSLAS Grade 50 Class 1-with Cu	56152	
HSLAS Grade 60 Class 1-with Cu	56162			
STRUCTURAL STEELS SUITABLE FOR COLD FORMING AND BENDING	ASTM A 1018 A 1018M-07	CS Type B	56830	38
		SS Grade 33	56833	
		SS 36 Type 1	56836	
		SS 36 Type 2-low Si	56837	
		SS 36 Type 2	56838	
		SS Grade 40	56840	

FLAT STEEL PRODUCT QUALITIES & USING AREAS				
Using Areas of Steel Qualities	Standard	Standard Quality	Colakoglu Quality ID	Page No.
MICRO ALLOYED STEELS SUITABLE FOR COLD FORMING AND BENDING	ASTM A 1018 A 1018M-07	HSLAS Grade 45 Class 1	56845	40
		HSLAS Grade 45 Class 2	56945	
		HSLAS Grade 50 Class 1	56850	
		HSLAS Grade 50 Class 1 -with Cu	55850	
		HSLAS Grade 50 Class 1-with Si	56851	
		HSLAS Grade 50 Class 1-with Cu+Si	55851	
		HSLAS Grade 55 Class 1	56855	
		HSLAS Grade 55 Class 1-with Si	56856	
		HSLAS Grade 50 Class 2	56950	
		HSLAS Grade 55 Class 2	56955	
		HSLAS Grade 60 Class 1	56860	
		HSLAS Grade 60 Class 2	56960	
		HSLAS Grade 65 Class 2	56965	
HSLAS Grade 70 Class 2	56970			
HSLAS-F Grade 80	56980			
UNALLOYED GENERAL STRUCTURAL STEELS	EN 10025 Part 2 -2004	S235JR	51235	42
		S235JR+N	51236	
		S235JR+Cu	55235	
		S235J2+N	52235	
		S275JR	51275	
		S275J2+N	52275	
UNALLOYED GENERAL STRUCTURAL STEELS	EN 10025 Part 2 -2004	E335	51335	43
UNALLOYED GENERAL STRUCTURAL STEELS	EN 10025- Part 2-2004	E335	51335	43
		S355J0	50355	
		S355JR	51355	
		S355J2	53355	
		S355J2+N	52355	
		S355J2+N-with Cu	55355	
UNALLOYED GENERAL STRUCTURAL STEELS SUITABLE FOR GALVANIZING AND BENDING	EN 10025- Part 2-2004	S235JR	54235	46
		S235JR (Cu+Cr+Ni≤0.35)	50236	
		S235J0 (Cu+Cr+Ni≤0.35)	50237	
		S235J0 (Cu+Cr+Ni≤0.35)	50238	
		S235J0	50235	
		S235J2	53235	
		S275JR	54275	
		S275J0	50275	
S275J2	53275			

FLAT STEEL PRODUCT QUALITIES & USING AREAS				
Using Areas of Steel Qualities	Standard	Standard Quality	Çolakoğlu Quality ID	Page No.
UNALLOYED GENERAL STRUCTURAL STEELS (SUITABLE FOR CLASS 1 TYPE GALVANIZING - STD.)	EN 10025- Part 2-2004	S355JR+N-low Si	54354	48
		S355JR-low Si	54355	
		S355J0-low Si	54356	
		S355J2+N-low Si	54357	
		S355J2-low Si	54358	
GENERAL STRUCTURAL STEELS SUITABLE FOR COLD FORMING, BENDING AND SPINNING	EN 10025 Part 2 -2004	S235JRC	40234	50
		S235J2C	40235	
		S235JRC+N	44235	
		S275JRC	43275	
		S275J2C	40275	
		S275JRC+N-Special	44276	
		S275J2C+N	44275	
GENERAL STRUCTURAL STEELS SUITABLE FOR COLD FORMING, BENDING AND SPINNING	EN 10025 Part 2-2004	S355JRC-low Si	42355	52
		S355J0C-low Si	41355	
		S355J2C-low Si	43355	
		S355J2C	40355	
		S355J2C+N	44355	
		S355JRC	40356	
HIGH STRENGTH NORMALISED STRUCTURAL STEELS SUITABLE FOR HOT FORMING	EN 10025 Part 3-2004	S420N-Special (SAH540)	52420	54
		S460N	52460	
		S355N	57355	
ATMOSPHERE CORROSION RESISTANT STEELS	EN 10025 Part 5-2004	S235J0W	58235	55
		S235J2W	58236	
		S355J0W	58355	
		S355J2W	58356	
		S355J0WP	58357	
		S355J2WP	58358	
WHEEL STEELS SUITABLE FOR COLD FORMING, BENDING AND SPINNING	EN 10025 Part 2-2004	S235JRC Special	82235	56
		S235J2C+N	81235	
		S275JRC	82280	
		S275JRC Special (S275J2C+N)	82290	
		S355JRC Special (S355J2C+N)	82330	
		S355J2C+N Special	82355	
		S355JRC Special	81330	
		S235JR-SS092 Rev 27	80235	
		S235JR-Special SS095 Rev 4	80236	
		S275J0-Special	80280	
		S275J2+N-Special	80290	
S355J0-Special	80355			

FLAT STEEL PRODUCT QUALITIES & USING AREAS

Using Areas of Steel Qualities	Standard	Standard Quality	Colakoglu Quality ID	Page No.
WHEEL STEELS SUITABLE FOR COLD FORMING, BENDING AND SPINNING	EN 10111 2008-06	DD11	81222	58
		DD 11-Special- 1	80122	
		DD 11-Special-2	80222	
HIGH STRENGTH WHEEL STEELS SUITABLE FOR COLD FORMING AND SPINNING	EN 10149 Part 2-1995	S355MC	83355	58
		S355MC-Special S5088 Rev 10	84355	
		S420MC (HL-2242-01)	83420	
		S460MC (HL-6000-02)	83460	
HIGH STRENGTH DUAL PHASE STEELS SUITABLE FOR COLD FORMING	EN 10338-2009	HCT500X (DP 500)	83500	59
HIGH STRENGTH DUAL PHASE WHEEL STEEL SUITABLE FOR COLD FORMING AND SPINNING	EN 10338-2010	HDT580X (DP 600)	83600	59
HOT ROLLED HIGH STRENGTH DUAL PHASE STEEL SUITABLE FOR COLD FORMING	EN 10338-2010	HCT600X (DP 600)	83610	59
		HCT780X (DP 780)	83780	
SPIRAL PIPE STEEL	EN 10025 Part 2-2004	S355JR-Special	92355	60
BOILER STEELS	EN 10028 Part 2-2008	P235GH	86235	61
		P265GH	86265	
		P295GH	86295	
		P355GH	86355	
BOILER STEELS	EN 10028 Part 3-2008	P355NL1	87355	61
STEELS SUITABLE TO USE UNDER LOW PRESSURE	EN 10207-2005	P275SL	86275	62
BOILER PIPE STEELS	EN 10217-2-2005	P235GH-low Si	86435	62
BOILER PIPE STEELS	EN 10217-3-2005	P275NL1-low Si	86475	63
LPG TUBE STEELS	EN 10120-2008	P245NB	85245	63
		P265NB	85265	
		P310NB	85310	
		P355NB	85355	

FLAT STEEL PRODUCT QUALITIES & USING AREAS				
Using Areas of Steel Qualities	Standard	Standard Quality	Çolakoğlu Quality ID	Page No.
GENERAL STRUCTURAL STEELS SUITABLE FOR HEAT TREATMENT	EN 10083 Part 2 -2006	28Mn6	98628	64
		C35E	98035	
		C35E-Cr	98135	
		C45E-Special	98145	
		C60E	98060	
		C60E-Special	98160	
GENERAL STRUCTURAL STEELS SUITABLE FOR HEAT TREATMENT	EN 10083 Part 3 -2006	C60E-1-Cr	98260	64
		30MnB5	98530	
		34MnB5	98534	
		27MnCrB5-2	98527	
		26MnB5	98526	
HIGH STRENGTH STEELS SUITABLE FOR COLD FORMING AND BENDING	EN 10149 Part 2-1995	22MnB5	98522	65
		S315MC	36315	
		S355MC	36355	
		S355MC-Special	36356	
		S420MC	36420	
		S420MC-with Si	36421	
		S460MC	36460	
		S460MC-with Si	36461	
		S500MC	36500	
		S500MC-with Si	36501	
		S550MC	36550	
		S550MC-with Si	36551	
MICRO ALLOYED STEELS SUITABLE FOR COLD ROLLING AND GALVANIZING	DIN EN 10025 Part2 -2004	S600MC	36600	66
		S650MC	36650	
MICRO ALLOYED STEELS SUITABLE FOR COLD FORMING AND GALVANIZING	EN 10149 Part 2-1995	S700MC	36700	67
		S275JR-Special	44277	
		S280MC-Special	37280	
		S315MC	37315	
		S355MC	37355	
		S420MC	37420	
		S420MC-HX420LAD	37421	
		S460MC	37460	
		S355MC-Special	37352	
S420MC-Special	37422			
S460MC-Special	37462			

FLAT STEEL PRODUCT QUALITIES & USING AREAS				
Using Areas of Steel Qualities	Standard	Standard Quality	Colakoglu Quality ID	Page No.
NORMALIZED ROLLED STEEL SUITABLE FOR COLD FORMING	BS 10149-Part 3-2013	S280NC-Special	38280	68
PRESSURE PIPE STEELS	EN 10217 Part 1-2005	P235TR1	94235	68
		P235TR2	94236	
		P235TR1-low Si	94035	
		P235TR2-low Si	94036	
LOW ALLOYED GENERAL STRUCTURAL STEELS SUITABLE FOR COLD DRAWING AND NORMALIZING (SUITABLE FOR CLASS 1 GALVANIZING STD.)	EN 10025 Part 2-2004	S355JR+N-low Si (Fe510DTCL)	54510	69
LOW ALLOYED GENERAL STRUCTURAL AND TUBE STEELS SUITABLE FOR NORMALISING	EN 10025 Part 2-2004	S355JR+N (Fe520DTCL)	51520	69
		S355JR+N (Fe510DTCL1)	51530	
UNALLOYED STRUCTURAL STEELS SUITABLE FOR HOT FORMING (SRM PIPE PRODUCTION), COLD ROLLING, NORMALIZING AND GALVANIZING	EN 10025 Part 2-2004	S235JR+N-low Si	41235	70
		S235JR+N	42235	
		S275JR+N-low Si	41275	
		S275J2+N-low Si	42275	
UNALLOYED STRAP STEELS FOR COLD ROLLING AND GALVANIZING	EN 10025 Part 2-2004	S235JR Strap Steel	51238	71
		S235JR Strap Steel with low Si	54238	
STRUCTURAL STEELS FOR SHIP BUILDING	ABS-Part 2-2013	ABS Grade A	57701	72
		ABS Grade B	57702	
UNALLOYED GENERAL STRUCTURAL STEEL	JIS G 3101-2005	S5400	93400	72
CHROME ADDED GENERAL STRUCTURAL STEELS	JIS G 3101-2005	S5400-with Cr	93430	73
BORON ADDED GENERAL STRUCTURAL STEELS	JIS G 3101-2005	S5400-with B	93420	73
HOT ROLLED LOW CARBON COMMERCIAL QUALITY STEELS SUITABLE FOR COLD FORMING	JIS G 3131-2005	SPHC	93111	74
LOW CARBON STEELS WITH BORON SUITABLE FOR COLD FORMING	JIS G 3131-2005	SPHC-with B	93211	74
HOT ROLLED LOW CARBON PIPE AND PROFILE STEELS SUITABLE FOR COLD FORMING AND GALVANIZING	JIS G 3132-2005	SPHT-1	93270	75
		SPHT-2	93340	
ATMOSPHERE CORROSION RESISTANT STEELS	JIS G 3125-2005	SPA-H	93125	75
UNALLOYED GENERAL STRUCTURAL STEELS SUITABLE FOR GALVANIZING AND BENDING	AS NZS 1594-2002	HA250-low Si	94250	76
UNALLOYED GENERAL STRUCTURAL STEELS SUITABLE FOR GALVANIZING AND BENDING	AS NZS 1594-2002	HA350-low Si	94350	76
UNALLOYED GENERAL STRUCTURAL STEELS	CSAG40	350 WT	96350	77
		44W/50W	96450	
HIGH STRENGTH STEELS SUITABLE FOR COLD FORMING AND BENDING	SAE J2340-1999-10	340XF	38340	77
		420XF	38420	

FLAT STEEL PRODUCT QUALITIES & USING AREAS				
Using Areas of Steel Qualities	Standard	Standard Quality	Çolakoglu Quality ID	Page No.
HOT ROLLED CARBON STEELS	SAE J403-2009	SAE 1006	91006	78
		SAE 1008	91008	
		SAE 1008-Modified	91108	
		SAE 1010	91010	
		SAE 1010-Modified	91110	
		SAE 1010 with Ca	91210	
		SAE 1012	91012	
		SAE 1012-High Mn	91112	
		SAE 1015	91015	
		SAE 1017	91017	
		SAE 1018	91018	
		SAE 1018-Modified	91118	
		SAE 1020	91020	
		SAE 1020-low Si	91121	
		SAE 1022-Modified	91022	
		HOT ROLLED MEDIUM AND HIGH CARBON STEELS	SAE J403-2001	
SAE 1045	91045			
SAE 1045-Special	91145			
SAE 1050	91050			
SAE 1055	91055			
SAE 1060	91060			
HOT ROLLED MEDIUM AND HIGH CARBON STEELS	SAE J404-2000	SAE 4130	92130	79
STEELS FOR PIPE LINES	API 5L 45th Edition-2012/ISO 3183-2012	A / L210 / PSL1	95130	79
		B / L245 / PSL1	95135	
		X42 / L290 / PSL1	95142	
		X46 / L320 / PSL1	95146	
		X52 / L360 / PSL1	95152	
		X56 / L390 / PSL1	95156	
		X52 / L360 / PSL1	95652	
		X60 / L415 / PSL1	95160	
		X65 / L450 / PSL1	95165	
		X70 / L485 / PSL1	95170	

FLAT STEEL PRODUCT QUALITIES & USING AREAS				
Using Areas of Steel Qualities	Standard	Standard Quality	Colakoglu Quality ID	Page No.
STEELS FOR PIPE LINES WITH STANDARD YIELD STRENGTH/TENSILE STRENGTH RATIO	API 5L 45th Edition-2012/ISO 3183-2012	BM / L245M / PSL2	95035	80
		BM / L245M / PSL2	95735	
		BM / L245M / PSL2	95036	
		X42M / L290M / PSL2	95042	
		X46M / L320M / PSL2	95046	
		X52M / L360M / PSL2	95752	
		X52M / L360M / PSL2	95052	
		X56M / L390M / PSL2	95056	
		X60M / L415M / PSL2	95060	
		X65M / L450M / PSL2	95065	
X70M / L485M / PSL2	95070			
STEELS FOR PIPE LINES WITH LOW YIELD STRENGTH/TENSILE STRENGTH RATIO	API 5LN-2012-PSL 2	BM / L245M / PSL2	95835	82
		X42M / L290M / PSL2	95842	
		X46M / L320M / PSL2	95846	
		X52M / L360M / PSL2	95852	
		X52M / L360M / PSL2	95952	
STEELS FOR PIPE LINES SUITABLE FOR SRM PIPE MANUFACTURING OR NORMALISING	API 5LN-2012	BN / L245N / PSL2	95535	83
		BN / L245N / PSL2	95536	
		X42N / L290N / PSL2	95542	
		X46N / L320N / PSL2	95546	
STEELS FOR PIPE LINES	EN ISO3183-2012 Annex M	L415NE PSL2 (API 5L X60NE)	95560	84
		L360NE PSL2 (API 5L X52NE)	95552	
STEELS FOR CASING AND/OR TUBING	API 5CT-2011	J55 Upgradeable (Tubing)	95254	85
		J55 Upgradeable (Casing)	95255	
		J55 Upgradeable	95256	
		J55 Upgradeable	95257	
		J55 Regular	95355	
		J55 Regular	95356	
UNALLOYED GENERAL STRUCTURAL STEELS (FLOOR PLATE)	ASTM A 36-2005 ASTM A786	ASTM A786 (ASTM A36)	56435	86
		ASTM A786 (ASTM A36)	56437	87

BILLET QUALITIES AND USING AREAS			
Using Area	Standart	Standard Quality	Page No.
CARBON STEEL	SAE J 403	SAE 1005	102
CARBON STEEL	SAE J 403	SAE 1006	
CARBON STEEL	SAE J 403	SAE 1008	
CARBON STEEL	SAE J 403	SAE 1010	
CARBON STEEL	SAE J 403	SAE 1012	
CARBON STEEL	SAE J 403	SAE 1015	
CARBON STEEL	SAE J 403	SAE 1018	
CARBON STEEL	SAE J 403	SAE 1020	
CARBON STEEL	SAE J 403	SAE 1030	
CARBON STEEL	SAE J 403	SAE 1035	
CARBON STEEL	SAE J 403	SAE 1040	
CARBON STEEL	SAE J 403	SAE 1045	
CARBON STEEL	SAE J 403	SAE 1050	
CARBON STEEL	SAE J 403	SAE 1055	
CARBON STEEL	SAE J 403	SAE 1060	

BILLET QUALITIES AND USING AREAS			
Using Area	Standard	Standard Quality	Page No.
REINFORCING STEEL BAR	ABNT NBR 7480 : 2017	CA 50	104
REINFORCING STEEL BAR	ACHM 7-93	A 500C	
REINFORCING STEEL BAR	ASTM A 615	GR 40	
REINFORCING STEEL BAR	ASTM A 615	GR 60	
REINFORCING STEEL BAR	ASTM A 615	GR 75	
REINFORCING STEEL BAR	ASTM A 706	GR 60	
REINFORCING STEEL BAR	BDS 9252 : 2007	B 500B	
REINFORCING STEEL BAR	BS 4449:1997	GR 460 B	
REINFORCING STEEL BAR	BS 4449:2005	B 500 B	
REINFORCING STEEL BAR	BS 4449:2005	B 500 C	
REINFORCING STEEL BAR	CAN/CSA.G30.18-09	GR 400R	
REINFORCING STEEL BAR	CAN/CSA.G30.18-09	GR 400W	
REINFORCING STEEL BAR	CAN/CSA.G30.18-09	GR 500R	
REINFORCING STEEL BAR	CAN/CSA.G30.18-09	GR 500W	
REINFORCING STEEL BAR	DIN 17100	St 50	
REINFORCING STEEL BAR	DIN 17100	St 60	
REINFORCING STEEL BAR	DIN 17100	St 37-2	
REINFORCING STEEL BAR	DIN 488: 2009	B 500 B	
REINFORCING STEEL BAR	DM 14.01.2008	B 450 C	
REINFORCING STEEL BAR	E 449 : 2010	A 400 NR	
REINFORCING STEEL BAR	E 450 : 2010	A 500 NR	
REINFORCING STEEL BAR	GOST 380	3SP	
REINFORCING STEEL BAR	GOST 380	5SP	
REINFORCING STEEL BAR	IS 6935-2 : 2007	B 500 BWR	
REINFORCING STEEL BAR	IS 4466-3 : 2013	S 400	
REINFORCING STEEL BAR	IS 4466-3 : 2013	S 400 W	
REINFORCING STEEL BAR	IS 4466-3 : 2013	S 500 W-C	
REINFORCING STEEL BAR	JS 33: 2013	GR 300	
REINFORCING STEEL BAR	JS 33: 2013	GR 400	
REINFORCING STEEL BAR	MS 146 : 2006	B 500 B	
REINFORCING STEEL BAR	NCh 206 : 2006	A 630- 420H	
REINFORCING STEEL BAR	NCh 206 : 2006	A 440- 280H	
REINFORCING STEEL BAR	NEN 6008:2008	B 500 B	
REINFORCING STEEL BAR	NF A 35-016:1986	FEE 400	
REINFORCING STEEL BAR	NF A 35-016:1996	FEE 500	
REINFORCING STEEL BAR	NF A 35- 080-1:2013	B 500 B	
REINFORCING STEEL BAR	NTC 2289:2012	GR 60	
REINFORCING STEEL BAR	SR 438-1:2012	OB 37	
REINFORCING STEEL BAR	SR 438-1:2012	PC 52	
REINFORCING STEEL BAR	TS 708 : 2016	B 420 B	
REINFORCING STEEL BAR	TS 708 : 2016	B 420C	
REINFORCING STEEL BAR	TS 708 : 2016	B 500 B	
REINFORCING STEEL BAR	TS 708 : 2016	B 500 C	
REINFORCING STEEL BAR	TS 708 : 2016	S 420	
REINFORCING STEEL BAR	INTE 06-09-01	GR 40	
REINFORCING STEEL BAR	INTE 06-09-01	GR 60	
REINFORCING STEEL BAR	INTE 06-09-02	GR 60	

REINFORCING BAR QUALITIES		
Standard	Standard Quality	Page No.
ABNT NBR 7480	CA 50	106
ACHM 7-93	A 500C	
ASTM A 615	GR 40	
ASTM A 615	GR 60	
ASTM A 615	GR 75	
ASTM A 706	GR 60	
BDS 9252:2007	B 500B	
BS 4449:1997	GR 460 B	
BS 4449:2005	B 500 B	
BS 4449:2005	B 500 C	
CAN/CSA G30.18-09	GR 400R	
CAN/CSA G30.18-09	GR 400W	
CAN/CSA G30.18-09	GR 500R	
CAN/CSA G30.18-09	GR 500W	
DIN 488:2009	B 500 B	
DM. 14/01/2008	B 450 C	
E 449 : 2010	A 400 NR	
E 450 : 2010	A 500 NR	
IS 6935-2 :2007	B 500 BWR	
IS 4466-3:2013	S 400	
IS 4466-3:2013	S 400 W	
IS 4466-3:2013	S 500 W-C	

REINFORCING BAR QUALITIES		
Standard	Standard Quality	Page No.
JS 33 : 2013	GR 300	106
JS 33 : 2013	GR 400	
MS 146 : 2006	GR 500 B	
NCh 204:2006	A 630- 420H	
NCh 204:2006	A 440- 280H	
NEN 6008:2008	B 500 B	
NF A35-080-1:2013	B 500 B	
NFA 35-016:1986	FEE 400	
NFA 35-016:1996	FEE 500	
NFA 35-080:2013	B 500B	
NTC 2289:2012	GR 60	
SR 438-1:2012	OB 37	
SR 438-1:2012	PC 52	
TS 708 : 2016	B 420 B	
TS 708 : 2016	B 420C	
TS 708 : 2016	B 500 B	
TS 708 : 2016	B 500 C	
TS 708 : 2016	S 420	
INTE 06-09-01	GR 40	
INTE 06-09-01	GR 60	
INTE 06-09-02	GR 60	

HELICAL ROD QUALITIES		
Standard	Standard Quality	Page No.
NCh 204 : 2006	A 630- 420H	111
NCh 204 : 2006	A 440- 280H	
DIN Material No 1.1165	St 450/700	





FLAT STEEL PRODUCTS

CHEMICAL &
MECHANICAL PROPERTIES

Slab	
Thickness:	200-250 mm
Width:	800-1650 mm
Length:	5.80-11.80 m

*Slab qualities are the same as
Hot Rolled Steel Qualities*

Hot Rolled Steel Coil (HRC)	
Thickness:	1.10-25.4
Width:	800-1650 mm
Coil Weight:	10-39 ton
Coil Inner Dia.:	762 mm

HOT ROLLED STEELS FOR COLD ROLLING AND GALVANIZING

Standard: DIN 1614-Part1-1986

Chemical Composition (%)

Colakoglu Quality ID	Standard	Quality		C	Mn	P	S	N ⁽¹⁾	Al
				max.	max.	max.	max.	max.	min.
20122	DIN 1614-1	St 22	Standard	0.10	0.45	0.035	0.035	0.007	—
25122	DIN 1614-1	St 22-low Cu	Standard	0.10	0.45	0.035	0.035	0.007	—
20123	DIN 1614-1	RRSt 23	Standard	0.10	0.45	0.030	0.030	—	0.020
20124	DIN 1614-1	St 24	Standard	0.08	0.40	0.025	0.025	—	0.020
30623	DIN 1614-1	RRSt 23-with B	Standard	0.10	0.45	0.035	0.035	—	0.020
30624	DIN 1614-1	St 24-with B	Standard	0.08	0.40	0.030	0.030	—	0.020

Explanations

- 1) The maximum value for nitrogen does not apply if the chemical composition shows a minimum aluminium content of 0.020 %.
- 2) Mechanical test is not applied.

HOT ROLLED LOW CARBON STEELS FOR COLD FORMING									
Standard: EN 10111-2008									
Chemical Composition (%)									
Colakoglu Quality ID	Standard	Quality ⁽¹⁾		C	Mn	P	S	N	Al
				max.	max.	max.	max.	max.	min.
30111 ⁽³⁾	EN 10111	DD11-low Cu	Standard	0.12	0.60	0.045	0.045	0.007	—
30112 ⁽⁴⁾	EN 10111	DD12	Standard	0.10	0.45	0.035	0.035	—	0.020
30113 ⁽⁴⁾	EN 10111	DD13	Standard	0.08	0.40	0.030	0.030	—	0.020
35111	EN 10111	DD11	Standard	0.12	0.60	0.045	0.045	—	—
34111	EN 10111	DD11 High strength	Standard	0.12	0.60	0.045	0.045	0.007	—
30612	EN 10111	DD12 with B	Standard	0.10	0.45	0.035	0.035	—	0.020
30613	EN 10111	DD13 with B	Standard	0.08	0.40	0.030	0.030	—	0.020

Explanations

- 1) All grades are produced as fully killed steel (Al ≥ % 0.02)
- 2) Cu = % 0.20 - 0.40
- 3) Guarantee period in usage is one month in Std. (When Al ≥ % 0.02, Guarantee period is 6 months.)
- 4) Guarantee period in usage is 6 months.

Mechanical Properties									
Colakoglu Quality ID	Standard	Quality	Re		Rm ⁽¹⁾	A(%)			Bending
			N/mm ²			A ₉₀		A ₅	(tran.; 180°)
			1.5 ≤ d < 2	2 ≤ d ≤ 8		1.5 ≤ d < 2	2 ≤ d < 3	3 ≤ d < 8	mrb
					max.	min.	min.	min.	d: thickness
30111	EN 10111	DD11-low Cu	170 - 360	170 - 340	440	23	24	28	1 d
30112	EN 10111	DD12	170 - 340	170 - 320	420	25	26	30	0
30113	EN 10111	DD13	170 - 330	170 - 310	400	28	29	33	0
35111	EN 10111	DD11	170 - 360	170 - 340	440	23	24	28	1 d
34111	EN 10111	DD11 High strength	170 - 360	170 - 340	440	23	24	28	1 d
30612	EN 10111	DD12 with B	170 - 340	170 - 320	420	25	26	30	0
30613	EN 10111	DD13 with B	170 - 330	170 - 310	400	28	29	33	0

Explanations

- 1) Tensile tests are applied to "Transverse" test samples.

HOT ROLLED STEELS SUITABLE FOR COLD ROLLING & GALVANISING

Std. : SAE J403-2009

Chemical Composition (%)

Colakoglu Quality ID	Standard	Quality		C	Mn	P	S	Cu	Ni	Cr	Mo	B
						max.	max.	max.	min.	max.	max.	ppm
21006	SAE J 403	SAE 1006	Standard	0.08	0.25-0.40	0.030	0.050	0.20	0.20	0.15	0.06	-
21106	SAE J 403	SAE 1006-low Mn	Standard	0.03-0.06	0.15-0.25	0.020	0.015	0.08	0.06	0.05	0.015	-
21606	SAE J 403	SAE 1006 with B	Standart	0.08	0.25-0.40	0.030	0.050	0.20	0.20	0.15	0.06	30 - 50
21008	SAE J 403	SAE 1008	Standard	0.10	0.30-0.50	0.030	0.050	0.20	0.20	0.15	0.06	-
21010	SAE J 403	SAE 1010	Standard	0.08-0.13	0.30-0.60	0.030	0.050	0.20	0.20	0.15	0.06	-
21110	SAE J 403	SAE 1010-high Mn	Standard	0.08-0.13	0.80-1.00	0.030	0.050	0.20	0.20	0.15	0.06	-
21112	SAE J 403	SAE 1012-high Mn	Standard	0.10-0.15	0.30-0.60	0.030	0.050	0.20	0.20	0.15	0.06	-
21118	SAE J 403	SAE 1018-low Mn	Standart	0.15-0.20	0.60-0.90	0.030	0.035	0.20	0.20	0.15	0.06	-

UNALLOYED GENERAL STRUCTURAL STEEL

Standard: ASTM A 36-2005

Chemical Composition (%)

Colakoglu Quality ID	Standard	Quality		C	Mn	P	S	Si
				max.	max.	max.	max.	max.
56036	ASTM A 36	A 36	Standard	0.25	0.80 - 1.20	0.040	0.050	0.40

Explanations

- 1) If the thickness is 20 mm and thinner, Mn % limit is not required.
- 2) For each reduction of 0.01 % for carbon, an increase of 0.06 % for manganese is permitted, up to a maximum of 1.35 %.
- 3) Optionally, 0.2 % Cu is permitted.

Mechanical Properties

Colakoglu Quality ID	Standard	Quality	Re	Rm ⁽¹⁾	A(%)		Impact	
			N/mm ²		A ₅₀	A ₂₀₀	Temp.	KVc
			(min.)	(min.)	min.	min.	C	J
56036	ASTM A 36	A 36	250	400 - 550	21	18	-20	40

Explanations

- 1) Tensile tests are applied to "Transverse" test samples.
- 2) Impact tests are not required if nominal thickness is lesser than 6 mm.
- 3) Impact tests are carried out if it is customer's request in order.

UNALLOYED GENERAL STRUCTURAL STEEL SUITABLE FOR GALVANIZING

Standard: ASTM A 36-2005

Chemical Composition (%)

Colakoglu Quality ID	Standard	Quality		C	Mn	P	S	Cu
				max.	max.	max.	max.	min.
56436	ASTM A 36	A 36-low Si	Standard	0.25	0.80 - 1.20	0.040	0.050	0.40

Explanations

- 1) If the thickness is 20 mm and thinner, Mn % limit is not required.
- 2) For each reduction of 0.01 % for carbon, an increase of 0.06 % for manganese is permitted, up to a maximum of 1.35 %.
- 3) Optionally, 0.2 % Cu is permitted.

Mechanical Properties

Colakoglu Quality ID	Standard	Quality	Re	Rm ⁽¹⁾	A(%)		Impact	
			N/mm ²		A ₅₀	A ₂₀₀	Temp.	KVc
			(min.)	(min.)	min.	min.	C	J
56436	ASTM A 36	A 36-low Si	250	400 - 550	23	20	-20	40

Explanations

- 1) Tensile tests are applied to "Transverse" test samples.
- 2) Impact tests are not required if nominal thickness is lesser than 6 mm.
- 3) Impact tests are carried out if it is customer's request in order.

UNALLOYED PIPE AND PROFILE STEELS

Standard: ASTM A53 Grade A

Chemical Composition (%)

Colakoglu Quality ID	Standard	Quality		C	Mn	P	S	Si	Cu ⁽¹⁾	Ni ⁽¹⁾	Cr ⁽¹⁾	Mo ⁽¹⁾	V ⁽¹⁾
			Std.	max.	max.	max.	max.	max.	max.	max.	max.	max.	max.
56053	ASTM A 53	Grade A	Std.	0.25	0.95	0.050	0.045	0.35	0.40	0.40	0.40	0.15	0.08

Explanations

1) Total weight of these elements are max. % 1.00 for ASTM A 53 Grade A.

Mechanical Properties

Colakoglu Quality ID	Standard	Quality	Re	Rm ⁽¹⁾	A ⁵⁰ (%)
			N/mm ²		
			min.	min.	min.
56053	ASTM A 53	Grade A	205	330	"2"

Explanations

1) Tensile tests are applied to "Longitudinal" test samples.

2) $A_{50} (\%) = 1940 S_0 0.2 / U0.9$ (S_0 : Cross sectional area, mm²; U: Tensile stress, N/mm²)

UNALLOYED PIPE AND PROFILE STEELS SUITABLE FOR GALVANIZING

Standard: ASTM A53 Grade A

Chemical Composition (%)

Colakoglu Quality ID	Standard	Quality		C	Mn	P	S	Si	Cu ⁽¹⁾	Ni ⁽¹⁾	Cr ⁽¹⁾	Mo ⁽¹⁾	V ⁽¹⁾
			Std.	max.	max.	max.	max.	max.	max.	max.	max.	max.	max.
56453 ⁽²⁾	ASTM A 53	Grade A-low Si	Std.	0.25	0.95	0.050	0.045	—	0.40	0.40	0.40	0.15	0.08

Explanations

1) Total weight of these elements are max. % 1.00 for ASTM A 53 Grade A.

2) 56453 with %Si ≤ 0.04 is suitable for galvanizing and cold forming.

Mechanical Properties

Colakoglu Quality ID	Standard	Quality	Re	Rm ⁽¹⁾	A ⁵⁰ (%)
			N/mm ²		
			min.	min.	min.
56453	ASTM A 53	Grade A-low Si	205	330	"2"

Explanations

1) Tensile tests are applied to "Longitudinal" test samples.

2) $A_{50} (\%) = 1940 S_0 0.2 / U0.9$ (S_0 : Cross sectional area, mm²; U: Tensile stress, N/mm²)

PIPE AND PROFILE STEELS

Standard: ASTM A53 Grade B

Chemical Composition (%)

Colakoglu Quality ID	Standard	Quality	Std.	C	Mn	P	S	Cu ⁽¹⁾	Ni ⁽¹⁾	Cr ⁽¹⁾	Mo ⁽¹⁾	V ⁽¹⁾
				max.	max.	max.	max.	max.	max.	max.	max.	
56052	ASTM A 53	Grade B-with Si	Std.	0.30	1.20	0.050	0.045	0.50	0.40	0.40	0.15	0.08

Explanations

1) Total weight of these elements are max. % 1.00 for ASTM A 53 Grade B.

Mechanical Properties

Colakoglu Quality ID	Standard	Quality	Re	Rm ⁽¹⁾	A ₅₀ (%)
			N/mm ²		
			min.	min.	min.
56052	ASTM A 53	Grade B-with Si	240	415	"2"

Explanations

1) Tensile tests are applied to "Longitudinal" test samples.

2) A₅₀ (%) = 1940 S₀ 0.2 / U0.9 (S₀: Cross sectional area, mm²; U: Tensile stress, N/mm²)

UNALLOYED PIPE AND PROFILE STEELS SUITABLE FOR GALVANIZING

Standard: ASTM A53 Grade B

Chemical Composition (%)

Colakoglu Quality ID	Standard	Quality	Std.	C	Mn	P	S	Si	Cu ⁽¹⁾	Ni ⁽¹⁾	Cr ⁽¹⁾	Mo ⁽¹⁾	V ⁽¹⁾
				max.	max.	max.	max.	max.	max.	max.	max.	max.	max.
56452	ASTM A 53	Grade B-low Si	Std.	0.30	1.20	0.050	0.045	—	0.40	0.40	0.40	0.15	0.08

Explanations

1) Total weight of these elements are max. % 1.00 for ASTM A 53 Grade B.

Mechanical Properties

Colakoglu Quality ID	Standard	Quality	Re	Rm ⁽¹⁾	A ₅₀ (%)
			N/mm ²		
			min.	min.	min.
56452	ASTM A 53	Grade B-low Si	240	415	"2"

Explanations

1) Tensile tests are applied to "Longitudinal" test samples.

2) A₅₀ (%) = 1940 S₀ 0.2 / U0.9 (S₀: Cross sectional area, mm²; U: Tensile stress, N/mm²)

UNALLOYED GENERAL STRUCTURAL STEEL

Standard: ASTM A 283-2003

Chemical Composition (%)

Colakoglu Quality ID	Standard	Quality		C	Mn ²⁾	P	S	Si	Cu
				max.	max.	max.	max.	max.	max.
56380	ASTM A 283	Grade C	Standard	0.24	0.90	0.035	0.040	0.40	0.20

Mechanical Properties

Colakoglu Quality ID	Standard	Quality	Re	Rm ¹⁾	A (%)	
			N/mm ²		A 50	A 200
			min.	min.	min.	min.
56380	ASTM A 283	Grade C	205	380 - 515	23	20

Explanations

1) Tensile tests are applied to "Transverse" test samples.

UNALLOYED PIPE AND PROFILE STEELS SUITABLE FOR GALVANIZING

Standard: ASTM A 500-2007

Chemical Composition (%)

Colakoglu Quality ID	Standard	Quality		C	Mn	P	S	Cu
				max.	max.	max.	max.	max.
56542	ASTM A 500	Grade B	Standard	0.26	1.35	0.035	0.035	0.20
56546	ASTM A 500	Grade C	Standard	0.23	1.35	0.035	0.035	0.20

Explanations

1) For each reduction of 0.01 % for carbon, an increase of 0.06 % for manganese is permitted, up to a maximum 1.50 %.

Mechanical Properties

Colakoglu Quality ID	Standard	Quality	Re	Rm ¹⁾	A (%)
			N/mm ²		A 50
			min.	min.	min.
56542	ASTM A 500	Grade B	290	400	23 ²
56546	ASTM A 500	Grade C	315	425	21 ³

Explanations

- 1) Tensile tests are applied to "Longitudinal" test samples.
- 2) Given elongation values are valid for 4.7 mm and thicker samples. % elongation = 2.40 d+12 formula is applied for the products with lower thickness than 4.7 mm.
- 3) Given elongation values are applied for 3.05 mm and thicker samples.

**CARBON STEEL SUITABLE FOR USING WITH A PRESSURE
AT MIDDLE & HIGH TEMPERATURES**

Standard: ASTM A 516-2010

Chemical Composition (%)

Colakoglu Quality ID	Standard	Quality		C	Mn	P	S	Si
				max.	max.	max.	max.	max.
56660	ASTM A 516-2010	ASTM A 516 Grade 60	Standard	0.23	0.6-1.2	0.025	0.025	0.15-0.40

Mechanical Properties

Colakoglu Quality ID	Standard	Quality	Re	Rm ⁽¹⁾	A 50 (%)
			N/mm ²		
			min.	min.	min.
56660	ASTM A 516-2010	ASTM A 516 Grade 60	220	415	25

HIGH STRENGTH LOW ALLOY STRUCTURAL STEELS

Standard: ASTM A572-2007

Chemical Composition (%)

Colakoglu Quality ID	Standard	Quality		C ⁽¹⁾	Mn ⁽³⁾	P	S	Si	Cu ⁽²⁾	V	Nb
				max.	max.	max.	max.	max.	min.		max.
56350	ASTM A 572	Grade 50 Type 1	Standard	0.23	0.8-1.35	0.04	0.05	0.40	0.20	-	0.005-0.05
56550	ASTM A 572	Grade 50 Type 2	Standard	0.23	0.8-1.35	0.04	0.05	0.40	0.20	0.01-0.15	0.05
56355	ASTM A 572	Grade 55 Type 1	Standard	0.25	0.8-1.35	0.04	0.05	0.40	0.20	-	0.005-0.05
56555	ASTM A 572	Grade 55 Type 2	Standard	0.25	0.8-1.35	0.04	0.05	0.40	0.20	0.01-0.15	-
56560	ASTM A 572	Grade 60 Type 1	Standard	0.26	0.8-1.35	0.04	0.05	0.40	0.20	-	0.005-0.05
56565	ASTM A 572	Grade 65 Type 1	Standard	0.23	0.80-1.65	0.04	0.05	0.40	0.20	-	0.005-0.05

Explanations

- 1) For each reduction of 0.01 % for carbon, an increase of 0.06 % for manganese is permitted, up to a maximum of 1.60.
- 2) When copper is specified, a minimum of 0.20 % is required.
- 3) Mn will be min %0.80 if the coil thickness bigger than 10 mm and will be min %0.50 if the coil thickness is equal or less than 10 mm.

Mechanical Properties

Colakoglu Quality ID	Standard	Quality	Re	Rm ⁽¹⁾	A(%)		Impact (long. ²)	
			N/mm ²		A ₅₀	A ₂₀₀	Temp.	KVc
			(min.)	(min.)	min.	min.	°C	J
56350	ASTM A 572	Grade 50 Type 1	345	450	21	18	+20	27
56550	ASTM A 572	Grade 50 Type 2	345	450	21	18	+20	27
56355	ASTM A 572	Grade 55 Type 1	380	485	20	17	+20	27
56555	ASTM A 572	Grade 55 Type 2	380	485	20	17	+20	27
56560	ASTM A 572	Grade 60 Type 1	415	520	18	16	+20	27
56565	ASTM A 572	Grade 65 Type 1	450	550	17	15	+20	27

Explanations

- 1) Tensile tests are applied to "Transversal" test samples.
- 2) Impact tests are carried out if it is customer's request in order.

MICROALLOYED HIGH STRENGTH STEEL RESISTANT TO ATMOSPHERE CORROSION							
Standard: ASTM A 606							
Chemical Composition (%)							
Çolakoğlu Quality ID	Standard	Quality		C	Mn	S	Cu
				max.	max.	max.	max.
55340	ASTM A 606	Type 2	Standard	0.22	1.25	0.04	0.20

Explanations

1) %C max. could be 0.15 in case %Mn is 1.40 max.

Mechanical Properties						
Çolakoğlu Quality ID	Standard	Quality	Re	Rm	A (%)	
			N/mm ²		A 50	
			min.	min.	min.	
55340	ASTM A 606	Type 2	340	480	22	

STRUCTURAL STEELS SUITABLE FOR COLD FORMING & BENDING

Standard: ASTM A 1011/A 1011M-07

Chemical Composition (%)

Colakoglu Quality ID	Standard	Quality		C	Mn	P	S	Si	Cu	Ni	Cr	Mo	V	Nb	Ti ⁽³⁾	Ca
				max.	max.	max.	max.	max.	max.	max.	max.	max.	max.	max.	max.	max.
56340	ASTM A 1011	CS Type B	Std.	0.15	0.60	0.030	0.035	-	0.20	0.20	0.15	0.06	0.008	0.008	0.025	0.0080
56360	ASTM A 1011	SS Grade 33	Std.	0.25	0.90	0.035	0.040	-	0.20	0.20	0.15	0.06	0.008	0.008	0.025	0.0080
56365	ASTM A 1011	SS 36 Type 1	Std.	0.25	0.90	0.035	0.040	-	0.20	0.20	0.15	0.06	0.008	0.008	0.025	0.0080
56400 ⁽¹⁾	ASTM A 1011	SS 36 Type 2	Std.	0.25	1.35	0.035	0.040	-	0.20	0.20	0.15	0.06	0.008	0.008	0.025	-
56275	ASTM A 1011	SS Grade 40	Std.	0.25	0.90	0.035	0.040	-	0.20	0.20	0.15	0.06	0.008	0.008	0.025	-
56454	ASTM A 1011	SS Grade 50-low Si	Std.	0.25	1.35	0.035	0.040	-	0.20	0.20	0.15	0.06	0.008	0.008	0.025	-
56450	ASTM A 1011	SS Grade 50	Std.	0.25	1.35	0.035	0.040	-	0.20	0.20	0.15	0.06	0.008	0.008	0.025	-
56484	ASTM A 1011	SS Grade 55-low Si	Std.	0.25	1.35	0.035	0.040	-	0.20	0.20	0.15	0.06	0.008	0.008	0.025	-
56480	ASTM A 1011	SS Grade 55	Std.	0.25	1.35	0.035	0.040	-	0.20	0.20	0.15	0.06	0.008	0.008	0.025	-

Explanations

- 1) For each reduction of 0.01 % for carbon, an increase of 0.06 % for manganese is permitted, up to a maximum of 1.50 %.
- 2) When copper is specified, a minimum of 0.20 % is required.
- 3) Ti/ N is max. 3.4.

STRUCTURAL STEELS SUITABLE FOR COLD FORMING & BENDING

Standard: ASTM A 1011/A 1011M-07

Mechanical Properties

Colakoglu Quality ID	Standard	Quality	Re	Rm ⁽¹⁾	A(%)			Bending
			N/mm ²		A 50		AZ00	(tran.; 90°)
					2.5≤T≤6.0	1.6≤T≤2.5	T≤6.0	mrb
			min.	min.	min.	min.	min.	d: thickness
56340	ASTM A 1011	CS Type B	205-340	-	-	-	-	-
56360	ASTM A 1011	SS Grade 33	230	360	23	22	18	1d
56365	ASTM A 1011	SS 36 Type 1	250	365	22	21	17	1.5d
56400	ASTM A 1011	SS 36 Type 2	250	400 - 550	21	20	16	2d
56275	ASTM A 1011	SS Grade 40	275	380	21	20	16	2d
56454	ASTM A 1011	SS Grade 50-low Si	340	450	17	16	12	2.5d
56450	ASTM A 1011	SS Grade 50	340	450	17	16	12	2.5d
56484	ASTM A 1011	SS Grade 55-low Si	380	480	15	14	10	3d
56480	ASTM A 1011	SS Grade 55	380	480	15	14	10	3d

Explanations

- 1) Tensile tests are applied to "Longitudinal" test samples.
- 2) Bending tests are carried out if it is customer's request in order.

MICROALLOYED STRUCTURAL STEELS SUITABLE FOR COLD FORMING & BENDING

Standard: ASTM A 1011/A 1011M-07

Chemical Composition (%)

Çolakoglu Quality ID	Std.	Quality	C	Mn		Si	P		S	Cr	Ni	Cu	Al	Mo	V	Ti	N ppm	Nb
				max.	min.		max.	min.										
56245 ⁽¹⁾	ASTM A 1011 / ASTM A 1011M	HSLAS Grade 45 Class 2	Std. 0.15	max. 1.35	-	max. 0.04	max. 0.15	max. 0.20	max. 0.04	max. 0.15	max. 0.20	max. 0.20	min. -	max. 0.06	min. 0.005	min. 0.005	max. -	min. 0.005
56150 ⁽¹⁾	ASTM A 1011 / ASTM A 1011M	HSLAS Grade 50 Class 1-low Si	Std. 0.23	max. 1.35	-	max. 0.04	max. 0.15	max. 0.20	max. 0.04	max. 0.15	max. 0.20	max. 0.20	min. -	max. 0.06	min. 0.005	min. 0.005	max. -	min. 0.005
56151 ⁽¹⁾	ASTM A 1011 / ASTM A 1011M	HSLAS Grade 50 Class 1	Std. 0.23	max. 1.35	0.14-0.25	max. 0.04	max. 0.15	max. 0.20	max. 0.04	max. 0.15	max. 0.20	max. 0.20	min. -	max. 0.06	min. 0.005	min. 0.005	max. -	min. 0.005
56250	ASTM A 1011 / ASTM A 1011M	HSLAS Grade 50 Class 2	Std. 0.15	max. 1.50	-	max. 0.04	max. 0.15	max. 0.20	max. 0.04	max. 0.15	max. 0.20	max. 0.20	min. -	max. 0.06	min. 0.005	min. 0.005	max. -	min. 0.005
56155 ⁽¹⁾	ASTM A 1011 / ASTM A 1011M	HSLAS Grade 55 Class 1-low Si	Std. 0.25	max. 1.35	-	max. 0.04	max. 0.15	max. 0.20	max. 0.04	max. 0.15	max. 0.20	max. 0.20	min. -	max. 0.06	min. 0.005	min. 0.005	max. -	min. 0.005
56156 ⁽¹⁾	ASTM A 1011 / ASTM A 1011M	HSLAS Grade 55 Class 1	Std. 0.25	max. 1.35	0.14-0.25	max. 0.04	max. 0.15	max. 0.20	max. 0.04	max. 0.15	max. 0.20	max. 0.20	min. -	max. 0.06	min. 0.005	min. 0.005	max. -	min. 0.005
56255	ASTM A 1011 / ASTM A 1011M	HSLAS Grade 55 Class 2	Std. 0.15	max. 1.35	-	max. 0.04	max. 0.15	max. 0.20	max. 0.04	max. 0.15	max. 0.20	max. 0.20	min. -	max. 0.06	min. 0.005	min. 0.005	max. -	min. 0.005
56160	ASTM A 1011 / ASTM A 1011M	HSLAS Grade 60 Class 1	Std. 0.26	max. 1.50	-	max. 0.04	max. 0.15	max. 0.20	max. 0.04	max. 0.15	max. 0.20	max. 0.20	min. -	max. 0.06	min. 0.005	min. 0.005	max. -	min. 0.005
56260	ASTM A 1011 / ASTM A 1011M	HSLAS Grade 60 Class 2	Std. 0.15	max. 1.50	-	max. 0.040	max. 0.15	max. 0.20	max. 0.040	max. 0.15	max. 0.20	max. 0.20	min. -	max. 0.06	min. 0.005	min. 0.005	max. -	min. 0.005
56270	ASTM A 1011 / ASTM A 1011M	HSLAS Grade 70 Class 2	Std. 0.15	max. 1.65	-	max. 0.040	max. 0.15	max. 0.20	max. 0.040	max. 0.15	max. 0.20	max. 0.20	min. -	max. 0.16	min. 0.005	min. 0.005	max. -	min. 0.005
56280	ASTM A 1011 / ASTM A 1011M	HSLAS-F Grade 80	Std. 0.15	max. 1.65	-	max. 0.020	max. 0.15	max. 0.20	max. 0.025	max. 0.15	max. 0.20	max. 0.20	min. -	max. 0.16	min. 0.005	min. 0.005	max. -	min. 0.005
56152	ASTM A 1011 / ASTM A 1011M	HSLAS Grade 50 Class 1-with Cu	Std. 0.23	max. 1.35	-	max. 0.040	max. 0.15	max. 0.20	max. 0.040	max. 0.15	max. 0.20	max. 0.20-0.30	min. -	max. 0.06	min. 0.005	min. 0.005	max. -	min. 0.005
56162	ASTM A 1011 / ASTM A 1011M	HSLAS Grade 60 Class 1-with Cu	Std. 0.26	max. 1.50	-	max. 0.040	max. 0.15	max. 0.20	max. 0.040	max. 0.15	max. 0.20	max. 0.20-0.30	min. -	max. 0.06	min. 0.005	min. 0.005	max. -	min. 0.005

Explanations

- 1) For each reduction of 0.01 % for carbon, an increase of 0.06 % for manganese is permitted, up to a maximum of 1.50 %.
- 2) ASTM A 1011/A 1011M-2007 Std. is valid for strip thickness T ≤ 6 mm coils.

MICROALLOYED STRUCTURAL STEELS SUITABLE FOR COLD FORMING & BENDING

Standard: ASTM A 1011/A 1011M-07

Mechanical Properties

Colakoglu Quality ID	Standard	Quality	Re	Rm ¹⁾	A(%)		Bending (tran.; 90°)
			N/mm ²		A ₅₀		
			min.	min.	T < 2.5	2.5 < T	
56245 ¹⁾	ASTM A 1011 / ASTM A 1011M	HSLAS Grade 45 Class 2	310	380	23	25	d: thickness 1.5d
56150 ¹⁾	ASTM A 1011 / ASTM A 1011M	HSLAS Grade 50 Class 1-low Si	340	450	20	22	2d
56151 ¹⁾	ASTM A 1011 / ASTM A 1011M	HSLAS Grade 50 Class 1	340	450	20	22	2d
56250	ASTM A 1011 / ASTM A 1011M	HSLAS Grade 50 Class 2	340	410	20	22	1.5d
56155 ¹⁾	ASTM A 1011 / ASTM A 1011M	HSLAS Grade 55 Class 1-low Si	380	480	18	20	2d
56156 ¹⁾	ASTM A 1011 / ASTM A 1011M	HSLAS Grade 55 Class 1	380	480	18	20	2d
56255	ASTM A 1011 / ASTM A 1011M	HSLAS Grade 55 Class 2	380	450	18	20	2d
56160	ASTM A 1011 / ASTM A 1011M	HSLAS Grade 60 Class 1	410	520	16	18	2.5d
56260	ASTM A 1011 / ASTM A 1011M	HSLAS Grade 60 Class 2	410	480	16	18	2d
56270	ASTM A 1011 / ASTM A 1011M	HSLAS Grade 70 Class 2	480	550	12	14	3d
56280	ASTM A 1011 / ASTM A 1011M	HSLAS-F Grade 80	550	620	16	18	2d
56152	ASTM A 1011 / ASTM A 1011M	HSLAS Grade 50 Class 1-with Cu	340	450	20	22	2d
56162	ASTM A 1011 / ASTM A 1011M	HSLAS Grade 60 Class 1-with Cu	410	520	16	18	2.5d

Explanations

- 1) Tensile tests are applied to "longitudinal" test samples.
- 2) Bending tests are carried out if it is customer's request in order.

STRUCTURAL STEELS SUITABLE FOR COLD FORMING & BENDING

Standard: ASTM A1018/A 1018M-07

Chemical Composition (%)

Çolakoğlu Quality ID	Standard	Quality	Chemical Composition (%)											
			C	Mn	P	S	Cu ²⁾	Ni	Cr	Mo	V	Nb	Ti ³⁾	N
56830	ASTM A 1018	CS Type B	max. 0.02-0.15	max. 0.60	max. 0.030	max. 0.035	max. 0.20	max. 0.20	max. 0.15	max. 0.06	max. 0.008	max. 0.008	max. 0.025	max.
56833	ASTM A 1018	SS Grade 33	Std. 0.25	1.50	0.035	0.040	0.20	0.12	0.10	0.02	0.008	0.008	0.025	0.014
56836	ASTM A 1018	SS 36 Type 1	Std. 0.25	1.50	0.035	0.040	0.20	0.20	0.15	0.06	0.008	0.008	0.025	0.014
56837 ¹⁾	ASTM A 1018	SS 36 Type 2-low Si	Std. 0.25	1.35	0.035	0.040	0.20	0.20	0.15	0.06	0.008	0.008	0.025	0.014
56838	ASTM A 1018	SS 36 Type 2	Std. 0.25	1.35	0.035	0.040	0.20	0.20	0.15	0.06	0.008	0.008	0.025	0.014
56840	ASTM A 1018	SS Grade 40	Std. 0.25	1.50	0.035	0.04	0.20	0.12	0.10	0.02	0.008	0.008	0.025	0.014

Explanations

- 1) Mn % is 0.80-1.20 for 20 mm and thicker strips. For each reduction of 0.01 % for carbon, an increase of 0.06 % for manganese is permitted, up to a maximum of 1.35.
- 2) When copper is specified, a minimum of 0.20 % is required.
- 3) Ti / N is max. 3 : 4.

STRUCTURAL STEELS SUITABLE FOR COLD FORMING & BENDING

Standard: ASTM A1018/A 1018M-07

Mechanical Properties

Çolakoglu Quality ID	Std.	Quality	Re		Rm ⁽¹⁾		A(%)		Impact (long.) ²		Bending (tran., 90°) min. dt thickness	
			min.	N/mm ²	min.	min.	A 50 T ≤ 25	A 200 4.5 ≤ T ≤ 25	Temp.	KVc		J
			min.		min.		min.		min.			min.
56830	ASTMA 1018	CS Type B	-	-	-	-	-	-	-	-	-	
56833	ASTMA 1018	SS Grade 33	230	360	22	16	+20	40	1d			
56836	ASTMA 1018	SS 36 Type 1	250	365	21	15	+20	40	1.5d			
56837	ASTMA 1018	SS 36 Type 2-low S1	250	400-550	21	18	+20	40	2d			
56838	ASTMA 1018	SS 36 Type 2	250	400-550	21	18	+20	40	2d			
56840	ASTMA 1018	SS Grade 40	275	380	19	14	+20	40	2d			

Explanations

- 1) Tensile tests are applied to "Transversal" test samples.
- 2) Impact and Bending tests are carried out if it is customer's request in order.

MICRO ALLOYED STEELS SUITABLE FOR COLD FORMING & BENDING

Standard: ASTM A1018/A 1018M-07

Çolakoglu Quality/ID	Standard	Quality	Chemical Composition (%)													
			C	Mn	P	S	Cu	Ni	Cr	Mo	V	Nb	Ti	Si		
			max.	max.	max.	max.	max.	max.	max.	max.	max.	max.	min.	min.	min.	max.
56845	ASTM A 1018 ASTM A 1018M	HSLAS Grade 45 Class 1	Std.	1.50	0.04	0.04	0.04	0.20	0.20	0.15	0.06	0.005	0.005	0.005	0.005	
56945	ASTM A 1018 ASTM A 1018M	HSLAS Grade 45 Class 2	Std.	1.50	0.04	0.04	0.04	0.20	0.20	0.15	0.06	0.005	0.005	0.005	0.005	
56850	ASTM A 1018 ASTM A 1018M	HSLAS Grade 50 Class 1	Std.	1.50	0.04	0.04	0.04	0.20	0.20	0.15	0.06	0.005	0.005	0.005	0.005	
55850	ASTM A 1018 ASTM A 1018M	HSLAS Grade 50 Class 1-with Cu	Std.	1.50	0.04	0.04	0.04	0.20	0.20	0.15	0.06	0.005	0.005	0.005	0.005	
56851	ASTM A 1018 ASTM A 1018M	HSLAS Grade 50 Class 1-with Si	Std.	1.50	0.04	0.04	0.04	0.20	0.20	0.15	0.06	0.005	0.005	0.005	0.005	0.14-0.25
55851	ASTM A 1018 ASTM A 1018M	HSLAS Grade 50 Class 1-with Cu+Si	Std.	1.50	0.04	0.04	0.04	0.20	0.20	0.15	0.06	0.005	0.005	0.005	0.005	0.14-0.25
56855	ASTM A 1018 ASTM A 1018M	HSLAS Grade 55 Class 1	Std.	1.50	0.04	0.04	0.04	0.20	0.20	0.15	0.06	0.005	0.005	0.005	0.005	
56856	ASTM A 1018 ASTM A 1018M	HSLAS Grade 55 Class 1-with Si	Std.	1.50	0.04	0.04	0.04	0.20	0.20	0.15	0.06	0.005	0.005	0.005	0.005	0.14-0.25
56950	ASTM A 1018 ASTM A 1018M	HSLAS Grade 50 Class 2	Std.	1.50	0.040	0.040	0.040	0.20	0.20	0.15	0.06	0.005	0.005	0.005	0.005	
56955	ASTM A 1018 ASTM A 1018M	HSLAS Grade 55 Class 2	Std.	1.50	0.04	0.04	0.04	0.20	0.20	0.15	0.06	0.005	0.005	0.005	0.005	
56860	ASTM A 1018 ASTM A 1018M	HSLAS Grade 60 Class 1	Std.	1.5	0.04	0.04	0.04	0.20	0.20	0.15	0.06	0.005	0.005	0.005	0.005	
56960	ASTM A 1018 ASTM A 1018M	HSLAS Grade 60 Class 2	Std.	1.50	0.04	0.04	0.04	0.20	0.20	0.15	0.06	0.005	0.005	0.005	0.005	
56965	ASTM A 1018 ASTM A 1018M	HSLAS Grade 65 Class 2	Std.	1.50	0.04	0.04	0.04	0.20	0.20	0.15	0.06	0.005	0.005	0.005	0.005	
56970	ASTM A 1018 ASTM A 1018M	HSLAS Grade 70 Class 2	Std.	1.65	0.04	0.04	0.040	0.20	0.20	0.15	0.16	0.005	0.005	0.005	0.005	
56980	ASTM A 1018 ASTM A 1018M	HSLAS-F Grade 80	Std.	1.65	0.020	0.025	0.025	0.20	0.20	0.15	0.16	0.005	0.005	0.005	0.005	

MICRO ALLOYED STEELS SUITABLE FOR COLD FORMING & BENDING									
Standard: ASTM A1018/A 1018M-07									
Mechanical Properties									
Celakoglu Quality ID	Standard	Quality	Re		Rm ⁽¹⁾		A (%)		Bending ⁽²⁾ (tran.; 90°) mrb
			N/mm ²		N/mm ²		A 50	A 200	
			min.	min.	min.	min.	T≥25	4.5≤T≤25	min.
56845	ASTM A 1018 /ASTM A 1018M	HSLAS Grade 45 Class 1	310	410	22	17	17	1.5d	
56945	ASTM A 1018 /ASTM A 1018M	HSLAS Grade 45 Class 2	310	380	22	17	17	1.5d	
56850	ASTM A 1018 /ASTM A 1018M	HSLAS Grade 50 Class 1	340	450	20	16	2d		
55850	ASTM A 1018 /ASTM A 1018M	HSLAS Grade 50 Class 1-with Cu	340	450	20	16	2d		
56851	ASTM A 1018 /ASTM A 1018M	HSLAS Grade 50 Class 1-with Si	340	450	20	16	2d		
55851	ASTM A 1018 /ASTM A 1018M	HSLAS Grade 50 Class 1-with Cu+Si	340	450	20	16	2d		
56855	ASTM A 1018 /ASTM A 1018M	HSLAS Grade 55 Class 1	380	480	18	15	2d		
56856	ASTM A 1018 /ASTM A 1018M	HSLAS Grade 55 Class 1-with Si	380	480	18	15	2d		
56950	ASTM A 1018 /ASTM A 1018M	HSLAS Grade 50 Class 2	340	410	20	16	1.5d		
56955	ASTM A 1018 /ASTM A 1018M	HSLAS Grade 55 Class 2	380	450	18	15	2d		
56860	ASTM A 1018 /ASTM A 1018M	HSLAS Grade 60 Class 1	410	520	16	14	2.5d		
56960	ASTM A 1018 /ASTM A 1018M	HSLAS Grade 60 Class 2	410	480	16	14	2d		
56965	ASTM A 1018 /ASTM A 1018M	HSLAS Grade 65 Class 2	450	520	14	12	2.5d		
56970	ASTM A 1018 /ASTM A 1018M	HSLAS Grade 70 Class 2	480	550	12	10	3d		
56980	ASTM A 1018 /ASTM A 1018M	HSLAS-F Grade 80	550	620	12	10	2d		

Explanations

- 1) Tensile tests are applied to "Transversal" test samples.
- 2) Bending tests are carried out if it is customer's request in order.

UNALLOYED GENERAL STRUCTURAL STEELS

Standard: EN 10025-Part 2-2004

Chemical Composition (%)

Colakoglu Quality ID	Standard	Quality		C (max.)		Mn	P	S	Cu	Al ⁽¹⁾	N ⁽¹⁾	Ceq ⁽²⁾	
				d≤16	16<d≤40							max.	max.
				min.	max.								
51235	EN 10025-2	S235JR	Standard	0.17	0.17	1.4	0.035	0.035	0.55	—	0.012	0.35	
51236	EN 10025-2	S235JR+N	Standard	0.17	0.17	1.4	0.025	0.025	0.55	0.200	—	0.35	
55235	EN 10025-2	S235JR+Cu	Standard	0.17	0.17	1.4	0.035	0.035	0.55	—	0.012	0.35	
52235	EN 10025-2	S235J2+N	Standard	0.17	0.17	1.4	0.025	0.025	0.55	0.020	—		
51275	EN 10025-2	S275JR	Standard	0.21	0.21	1.5	0.035	0.035	0.55	—	0.012	0.40	
52275	EN 10025-2	S275J2+N	Standard	0.18	0.18	1.5	0.025	0.025	0.55	0.020	—	0.40	

Explanations

- 1) The maximum value for nitrogen does not apply if the chemical composition shows a minimum aluminium content of 0.020 %.
- 2) Ceq is calculated by $\%CE (IIW) = C + Mn/6 + (C + Mo + V)/5 + (Ni + Cr)/15$ formula.

Mechanical Properties

Colakoglu Quality ID	Std.	Quality	Re		Rm ⁽⁴⁾		A(%) min.					Impact (long.) ⁽²⁾	
			N/mm ²		N/mm ²		A ₉₀			A ₅	Temp.	KVC	
			min.	min.			d : thickness, mm						
			d : thickness, mm		d : thickness, mm								
			≤16	16<d≤40	<3	3≤d<40	1<d≤1.5	1.5<d≤2	2<d≤2.5	2.5<d≤3	3≤d≤40	°C	J
51235	EN 10025-2	S235JR	235	225	360 - 510	360 - 510	16	17	18	19	24	+20	27 ⁽³⁾
51236	EN 10025-2	S235JR+N	235	225	360 - 510	360 - 510	16	17	18	19	24	+20	27
55235	EN 10025-2	S235JR+Cu	235	225	360 - 510	360 - 510	16	17	18	19	24	+20	27
52235	EN 10025-2	S235J2+N	235	225	360 - 510	360 - 510	16	17	18	19	24	-20	27
51275	EN 10025-2	S275JR	275	265	430 - 580	410 - 560	14	15	16	17	21	+20	27 ⁽³⁾
52275	EN 10025-2	S275J2+N	275	265	430 - 580	410 - 560	14	15	16	17	21	-20	27

Explanations

- 1) Grades with N code can be normalized and/or hot formed by customers.
- 2) Impact tests are not required if nominal thickness is lesser than 6 mm.
- 3) Impact tests are carried out if it is customer's request in order.
- 4) Tensile tests are applied to "Transversal" test samples.

UNALLOYED GENERAL STRUCTURAL STEELS

Standard: EN 10025-Part 2-2004

Chemical Composition (%)

Colakoglu Quality ID	Standard	Quality		P	S	Cu	N
				max.	max.	max.	max.
51335	EN 10025-2	E335	Standard	0.045	0.045	0.55	120

Mechanical Properties

Colakoglu Quality ID	Std.	Quality	Re		Rm ⁽²⁾		A (%), min						Impact (long.) ³⁾	
			N/mm ²		N/mm ²		A ₈₀			A 5			Temp.	KVc
			min.	min.	d : thickness, mm				d : thickness, mm					
			d : thickness, mm											
			≤16	16<d≤40	<3	3≤d<100	1<d≤1.5	1.5<d≤2	2<d≤2.5	2.5<d≤3	3≤d≤40	°C	J	
51235	EN 10025-2	S235JR	235	225	360 - 510	360 - 510	16	17	18	19	24	+20	27 ⁽³⁾	

Explanations

- 1) Tensile tests are applied to "Transversal" test samples.
- 2) Impact tests are not carried out if nominal thickness is lesser than 6 mm.
- 3) Impact tests are carried out if it is customer's request in order.

UNALLOYED GENERAL STRUCTURAL STEELS

Standard: EN 10025-Part 2:2004

Çolakoğlu Quality ID	Standard	Quality	Chemical Composition (%)																	
			C (max.)	Si	Mn	P	S	Cu	Al ⁽¹⁾	N ⁽¹⁾	Ceq ⁽²⁾									
			d≤16	16<d≤40																
50355	EN 10025-2	S355J0	Std.	0.20	0.20	0.55	1.6	0.030	0.030	0.030	0.55	—	0.012	0.45						
51355	EN 10025-2	S355JR	Std.	0.24	0.24	0.55	1.6	0.035	0.035	0.035	0.55	—	0.012	0.45						
53355	EN 10025-2	S355J2	Std.	0.20	0.20	0.55	1.6	0.025	0.025	0.025	0.55	—	—	0.45						
52355	EN 10025-2	S355J2+N	Std.	0.20	0.20	0.55	1.6	0.025	0.025	0.025	0.55	0.020	—	0.45						
55355	EN 10025-2	S355J2+N-with Cu	Std.	0.20	0.20	0.55	1.6	0.025	0.025	0.025	0.55	—	—	0.45						

Explanations

- 1) The maximum value for nitrogen does not apply if the chemical composition shows a minimum aluminium content of 0.020 %.
- 2) Ceq is calculated by $\%Ceq = (C + Mn/6 + (Cr + Mo + V)/5 + (Ni + Cr)/15)$ formula.

UNALLOYED GENERAL STRUCTURAL STEELS

Standard: EN 10025-Part 2-2004

Mechanical Properties

Colokloglu Quality ID	Standard	Quality	Re		Rm ²⁰		A(%) ³⁾ , min.				Impact (long. ³⁾)		
			N/mm ²		N/mm ²		A ₅₀		A ₅		Temp.	KV _C min.	
			min.	min.	d : thickness, mm		d : thickness, mm		d : thickness, mm				
			≤16	16<d≤40	<3	3≤d<40	1<d≤1.5	1.5<d≤2	2<d≤2.5	2.5<d≤3	3≤d≤40		
50355	EN 10025-2	S355J0	355	345	510-680	470-630	13	14	15	16	20	0	27 ⁴⁾
51355	EN 10025-2	S355JR	355	345	510-680	470-630	13	14	15	16	20	+20	27
53355	EN 10025-2	S355J2	355	345	510-680	470-630	13	14	15	16	20	-20	27 ⁴⁾
52355	EN 10025-2	S355J2+N¹⁾	355	345	510-680	470-630	13	14	15	16	20	-20	27
55355	EN 10025-2	S355J2+N+Cu¹⁾	355	345	510-680	470-630	13	14	15	16	20	-20	27 ⁴⁾

Explanations

- 1) Grades with +N code can be normalized and/or hot formed by customers.
- 2) Tensile tests are applied to "Transversal" test samples.
- 3) Impact tests are not carried out if nominal thickness is lesser than 6 mm.
- 4) Impact tests are carried out if it is customer's request in order.

UNALLOYED GENERAL STRUCTURAL STEELS SUITABLE FOR GALVANIZING AND BENDING												
Standard: EN 10025 Part 2:2004												
Chemical Composition (%)												
Çolakoğlu Quality ID	Standard	Quality	C (max.)		Mn	P	S	Cu	Al ⁽¹⁾	N ⁽¹⁾	Ceq ⁽²⁾	max.
			d≤16	16<d≤40								
54235	EN 10025-2	S235JR	Std.	0.17	1.40	0.035	0.035	0.55	—	0.012	0.35	max.
50236	EN 10025-2	S235JR (Cu+Cr+Ni≤0.35)	Std.	0.17	1.4	0.035	0.035	0.55	—	0.012	0.35	
50237	EN 10025-2	S235J0 (Cu+Cr+Ni≤0.35)	Std.	0.17	1.4	0.030	0.030	0.55	—	0.012	0.35	
50238	EN 10025-2	S235J0 (Cu+Cr+Ni≤0.35)	Std.	0.17	1.4	0.035	0.035	0.55	—	0.012	0.35	
50235	EN 10025-2	S235J0	Std.	0.17	1.4	0.030	0.030	0.55	—	0.012	0.35	
53235	EN 10025-2	S235J2	Std.	0.17	1.4	0.025	0.025	0.55	—	0.012	0.35	
54275	EN 10025-2	S275JR	Std.	0.21	1.5	0.035	0.035	0.55	—	0.012	0.40	
50275	EN 10025-2	S275J0	Std.	0.18	1.5	0.030	0.030	0.55	—	0.012	0.40	
53275	EN 10025-2	S275J2	Std.	0.18	1.5	0.025	0.025	0.55	—	0.012	0.40	

Explanations

- 1) The maximum value for nitrogen does not apply if the chemical composition shows a minimum aluminium content of 0.020 %.
- 2) Ceq is calculated by %CE (lWM) = C+Mn/6+(C+Mo+V)/5+(Ni+Cr)/15 formula.

UN ALLOYED GENERAL STRUCTURAL STEELS SUITABLE FOR GALVANIZING AND BENDIN

Standard: EN 10025 Part 2:2004

		Mechanical Properties													
Coil/coil Quality/ID	Standard	Quality	Re		Rm ⁽¹⁾		A(%) _{min.}			Impact (long.) ⁽³⁾					
			N/mm ²		N/mm ²		A ₅₀	A ₅	Temp.		KJc				
			min.	min.	min.	min.	d : thickness, mm		°C	J	min.				
			d : thickness, mm	d : thickness, mm	d : thickness, mm	d : thickness, mm	1 < d ≤ 1,5	1,5 < d ≤ 2	2 < d ≤ 2,5	2,5 < d ≤ 3	3 ≤ d ≤ 40	°C	J		
54235	EN 10025-2	S235JR	≤16	16 < d ≤ 40	<3	3 ≤ d < 40	360 - 510	360 - 510	16	17	18	19	24	+20	27 ⁽¹⁾
50236	EN 10025-2	S235JR (Cu+Cr+Ni ≤ 0,35)	235	225	360 - 510	360 - 510	360 - 510	16	17	18	19	24	+20	27 ⁽¹⁾	
50237	EN 10025-2	S235J0 (Cu+Cr+Ni ≤ 0,35)	235	225	360 - 510	360 - 510	360 - 510	16	17	18	19	24	0	27 ⁽¹⁾	
50238	EN 10025-2	S235J0 (Cu+Cr+Ni ≤ 0,35)	235	225	360 - 510	360 - 510	360 - 510	16	17	18	19	24	0	27 ⁽¹⁾	
50235	EN 10025-2	S235J0	235	225	360 - 510	360 - 510	360 - 510	16	17	18	19	24	0	27 ⁽¹⁾	
53235	EN 10025-2	S235J2	235	225	360 - 510	360 - 510	360 - 510	16	17	18	19	24	-20	27 ⁽¹⁾	
54275	EN 10025-2	S275JR	275	265	430 - 580	410 - 560	410 - 560	14	15	16	17	21	+20	27 ⁽¹⁾	
50275	EN 10025-2	S275J0	275	265	430-580	410-560	410-560	14	15	16	17	21	0	27	
53275	EN 10025-2	S275J2	275	265	430-580	410-560	410-560	14	15	16	17	21	-20	27	

Explanations

- 1) Tensile tests are applied to "Transversal" test samples.
- 2) Impact tests are not carried out if nominal thickness is lesser than 6 mm.
- 3) Impact tests are carried out if it is customer's request in order.

**UNALLOYED GENERAL STRUCTURAL STEELS
(SUITABLE TO CLASS 1 TYPE GALVANIZING STANDARD)**

Standard: EN 10025 Part 2-2.004

Çolakoglu Quality ID	Standard	Quality	Chemical Composition (%)										
			C (max.)		Si	Mn	P	S	Cu	Al ⁽¹⁾	N ⁽¹⁾	Ceq ⁽²⁾	
			d≤16	16<d≤40									
54354	EN 10025-2	S355JR+N ⁽¹⁾ -low Si	Std.	0.24	0.24	0.55	1.6	0.035	0.035	0.55	—	0.012	0.45
54355	EN 10025-2	S355JR-low Si	Std.	0.24	0.24	0.55	1.6	0.035	0.035	0.55	—	0.012	0.45
54356	EN 10025-2	S355J0-low Si	Std.	0.20	0.20	0.55	1.6	0.030	0.030	0.55	—	0.012	0.45
54357	EN 10025-2	S355J2+N-low Si	Std.	0.20	0.20	0.55	1.6	0.025	0.025	0.55	—	—	0.45
54358	EN 10025-2	S355J2-low Si	Std.	0.20	0.20	0.55	1.6	0.025	0.025	0.55	—	—	0.45

Explanations

1) The maximum value for nitrogen does not apply if the chemical composition shows a minimum aluminium content of 0.020%.

2) Ceq is calculated by %CE (IIW) = C+Mn(6+(C+Mo+V)/5)+(Ni+Cr)/15 formula.

UNALLOYED GENERAL STRUCTURAL STEELS (SUITABLE TO CLASS 1 TYPE GALVANIZING STANDARD)

Standard: EN 10025 Part 2:2004

Mechanical Properties

Catalogue Quality ID	Std.	Quality	Re		Rm ⁽²⁾		A(%) min.				Impact (long.) ³		
			min.	min.	N/mm ²	Rm	A ₈₀		A ₅	Temp.	KJc min.		
							d : thickness, mm	d : thickness, mm					
			≤16	16<d≤40	<3	3≤d<40	1<d≤1.5	1.5<d≤2	2<d≤2.5	2.5<d≤3	3≤d≤40	°C	J
54354	EN 10025-2	S355JR+N ⁽¹⁾ -low Si	355	345	510-680	470-630	13	14	15	16	20	+20	27 ⁽⁴⁾
54355	EN 10025-2	S355JR-low Si	355	345	510-680	470-630	13	14	15	16	20	+20	27 ⁽⁴⁾
54356	EN 10025-2	S355J0-low Si	355	345	510-680	470-630	13	14	15	16	20	0	27 ⁽⁴⁾
54357	EN 10025-2	S355J2+N ⁽¹⁾ -low Si	355	345	510-680	470-630	13	14	15	16	20	-20	27 ⁽⁴⁾
54358	EN 10025-2	S355J2-low Si	355	345	510-680	470-630	13	14	15	16	20	-20	27 ⁽⁴⁾

Explanations

- 1) Grades with N code can be normalized and/or hot formed by customers.
- 2) Tensile tests are applied to "transversal" test samples.
- 3) Impact tests are not carried out if nominal thickness is lesser than 6 mm.
- 4) Impact tests are carried out if it is customer's request in order.

GENERAL STRUCTURAL STEELS SUITABLE FOR COLD FORMING, BENDING AND SPINNING

Standard: EN 10025-Part 2:2004

Çolakoğlu Quality ID	Standard	Quality	Chemical Composition (%)									
			C (max.)		Mn max.	P max.	S max.	Ca ppm	Al ⁽¹⁾ min.	Ce _{eq} ⁽²⁾ max.		
d≤16	16<d≤40	Std.	Std.	Std.							Std.	Std.
40234	EN 10025-2	S235JRC	0.17	0.17	1.4	0.035	0.035	20	0.020	0.35		
40235	EN 10025-2	S235J2C	0.17	0.17	1.4	0.025	0.025	20	0.020	0.35		
44235	EN 10025-2	S235JRC+N	0.17	0.17	1.4	0.035	0.035	20	0.020	0.35		
43275	EN 10025-2	S275JRC	0.21	0.21	1.5	0.035	0.035	0.55	0.020	0.40		
40275	EN 10025-2	S275J2C	0.18	0.18	1.5	0.025	0.025	20	0.020	0.40		
44276	EN 10025-2	S275JRC+N Special	0.21	0.21	1.5	0.035	0.035	0.55	0.020	0.40		
44275	EN 10025-2	S275J2C+N	0.18	0.18	1.5	0.025	0.025	20	0.020	0.40		

Explanations

- 1) The maximum value for nitrogen does not apply if the chemical composition shows a minimum aluminium content of 0.020 %.
- 2) Ce_{eq} is calculated by %C/(100) = C+Mn/6+(C+Mn+V)/5+(Ni+Cr)/15 formula.

GENERAL STRUCTURAL STEELS SUITABLE FOR COLD FORMING, BENDING & SPINNING

Standard: EN 10025-Part 2-2004

		Mechanical Properties													
Çeliköçlü Quality ID	Standard	Quality	Re		N/mm ²		Rm ^(b)		A(%)		Impact (long.) ^(d)				
			min.	min.	min.	min.	min.	min.	A ₅₀	A ₅	Temp.	K _{IC} min.			
													d : thickness, mm		d : thickness, mm
			d : thickness, mm		d : thickness, mm		d : thickness, mm		d : thickness, mm		d : thickness, mm		d : thickness, mm		
			≤16	16<d≤40	<3	3≤d<40	360-510	360-510	16	17	18	19	24	+20	27 ^(a)
40234	EN 10025-2	S235JR ^(c)	235	225	360-510	360-510	360-510	360-510	16	17	18	19	24	+20	27 ^(a)
40235	EN 10025-2	S235ZC	235	225	360-510	360-510	360-510	360-510	16	17	18	19	24	-20	27 ^(a)
44235	EN 10025-2	S235JR+N ⁽¹⁾⁽²⁾	235	225	360-510	360-510	360-510	360-510	16	17	18	19	24	+20	27 ^(a)
43275	EN 10025-2	S275JR ^(c)	275	265	430-580	410-560	410-560	410-560	14	15	16	17	21	+20	27 ^(a)
40275	EN 10025-2	S275ZC	275	265	430-580	410-560	410-560	410-560	14	15	16	17	21	-20	27 ^(a)
44276	EN 10025-2	S275JR+N-Special	275	265	430-580	410-560	410-560	410-560	14	15	16	17	21	+20	27 ^(a)
44275	EN 10025-2	S275ZC+N ⁽¹⁾⁽²⁾	275	265	430-580	410-560	410-560	410-560	14	15	16	17	21	-20	27 ^(a)

Explanations

- 1) Grades with N code can be normalized and/or hot formed by customers.
- 2) Grades with C code can be cold formed and/or cold flanged by customers.
- 3) Tensile tests are applied to "Transversal" test samples.
- 4) Impact tests are not carried out if nominal thickness is less than 6 mm.
- 5) Impact tests are carried out if it is customer's request in order.

		Mechanical Properties												
Çeliköçlü Quality ID	Standard	Quality	Bending ^(b) (tran. < 90°, mrb)											
			thickness d (mm)											
			6<d≤7	7<d≤8	8<d≤10	10<d≤12	12<d≤14	14<d≤16	16<d≤18	18<d≤20				
40234	EN 10025-2	S235JR ^(c)	10	12	16	20	25	28	36	40				
40235	EN 10025-2	S235ZC	10	12	16	20	25	28	35	40				
44235	EN 10025-2	S235JR+N	10	12	16	20	25	28	36	40				
43275	EN 10025-2	S275JR ^(c)	12	16	20	25	28	32	40	45				
40275	EN 10025-2	S275ZC	12	16	20	25	28	32	40	45				
44275	EN 10025-2	S275JR+N	12	16	20	25	28	32	40	45				

GENERAL STRUCTURAL STEELS SUITABLE FOR COLD FORMING, BENDING AND SPINNING

Standard : EN 10025-Part 2-2004

Çolakoğlu Quality ID	Standard	Quality	Chemical Composition (%)										
			C (max.)		Si	Mn	P	S	Cu	Al ⁽¹⁾	N ⁽¹⁾	Ce ⁽²⁾	
			d≤16	16<d≤40									
42355	EN 10025-2	S355JRC-low Si	Std.	0.24	0.55	1.6	0.035	0.035	0.55	—	0.012	0.45	
41355	EN 10025-2	S355J0C-low Si	Std.	0.24	0.55	1.6	0.035	0.035	0.55	—	0.012	0.45	
43355	EN 10025-2	S355J2C-low Si	Std.	0.20	0.55	1.6	0.025	0.025	0.55	—	—	0.45	
40355	EN 10025-2	S355J2C	Std.	0.20	0.55	1.6	0.025	0.025	0.55	0.020	—	0.45	
44355	EN 10025-2	S355J2C+N	Std.	0.20	0.55	1.6	0.025	0.025	0.55	0.020	—	0.45	
40356	EN 10025-2	S355JRC	Std.	0.24	0.55	1.6	0.035	0.035	0.55	—	0.012	0.45	
44356	EN 10025-2	S355J2C+N-Special	Std.	0.20	0.55	1.7	0.025	0.025	0.55	0.020	—	0.45	

Explanations

- 1) The maximum value for nitrogen does not apply if the chemical composition shows a minimum aluminium content of 0.020 %.
- 2) Ceq is calculated by %Ce (100) = C+Mn/6+(Cr+Mo+V)/5+(Ni+Cu)/15 formula.

GENERAL STRUCTURAL STEELS SUITABLE FOR COLD FORMING, BENDING & SPINNING

Standard: EN 10025-Part 2:2004

Colokloglu Quality ID		Standard	Quality	Re		Rm ⁽³⁾		A(%)				Impact (long.) ⁽⁴⁾		
				N/mm ²		N/mm ²		A ₉₀		A ₅		Temp.	KV _C min.	
				min.	min.	d : thickness, mm		d : thickness, mm		d : thickness, mm				
				≤16	16 < d ≤ 40	< 3	3 < d < 40	1 < d ≤ 1.5	1.5 < d ≤ 2	2 < d ≤ 2.5	2.5 < d ≤ 3	3 ≤ d ≤ 40		
42355	EN 10025-2	S355JRC-low S1	355	345	510-680	470-630	13	14	15	16	20	20	+20	27 ⁽⁵⁾
41355	EN 10025-2	S355J0C-low S1	355	345	510-680	470-630	13	14	15	16	20	20	0	27 ⁽⁵⁾
43355	EN 10025-2	S355J2C-low S1	355	345	510-680	470-630	13	14	15	16	20	20	-20	27 ⁽⁵⁾
40355	EN 10025-2	S355J2C	355	345	510-680	470-630	13	14	15	16	20	20	-20	27 ⁽⁵⁾
44355	EN 10025-2	S355J2C+N	355	345	510-680	470-630	13	14	15	16	20	20	-20	27 ⁽⁵⁾
40356	EN 10025-2	S355JRC	355	345	510-680	470-630	13	14	15	16	20	20	+20	27 ⁽⁵⁾
44356	EN 10025-2	S355J2C+H-Special	355	345	510-680	470-630	13	14	15	16	20	20	-20	27 ⁽⁵⁾

Explanations

- 1) Grades with N code can be normalized and/or hot formed by customers.
- 2) Grades with C code can be cold formed and/or cold flanged by customers.
- 3) Tensile tests are applied to "Transversal" test samples.
- 4) Impact tests are not carried out if nominal thickness is lesser than 6 mm.
- 5) Impact tests are carried out if it is customer's request in order.

Colokloglu Quality ID		Standard	Quality	Bending ⁽¹⁾ (trans., ≤90°, mb)										
				thickness, d (mm)										
				6 < d ≤ 7	7 < d ≤ 8	8 < d ≤ 10	10 < d ≤ 12	12 < d ≤ 14	14 < d ≤ 16	16 < d ≤ 18	18 < d ≤ 20			
42355	EN 10025-2	S355JRC-low S1	—	—	—	—	—	—	—	—	—	—	—	—
43355	EN 10025-2	S355J2C-low S1	12	16	20	25	32	36	45	50	—	—	—	—
40355	EN 10025-2	S355J2C	12	16	20	25	32	36	45	50	—	—	—	—
44355	EN 10025-2	S355J2C+N	12	16	20	25	32	36	45	50	—	—	—	—
40356	EN 10025-2	S355JRC	—	—	—	—	—	—	—	—	—	—	—	—
44356	EN 10025-2	S355J2C+H-Special	12	16	20	25	32	36	45	50	—	—	—	—

Explanations

- 1) The values for bending tests are applied to 90° and acute angles.

HIGH STRENGTH NORMALISED STRUCTURAL STEELS SUITABLE FOR HOT FORMING

Standard: EN 10025 Part 3 - 2004

Chemical Composition (%)

Çolakoğlu Quality ID	Standard	Quality	Chemical Composition (%)													
			C	Mn	Si	P	S	Nb	V	Ti	Mo	Cr	Ni	Cu	Al	N ppm
52420	EN 10025-3	5420N-Special (SAH540)	max. 0.20	1.00-1.70	0.60	0.030	0.025	0.05	0.20	0.05	0.10	0.30	0.80	0.55	0.02	0.025
52460	EN 10025-3	5460N	Std. 0.20	1.00-1.70	0.60	0.030	0.025	0.05	0.20	0.05	0.10	0.30	0.80	0.55	0.02	0.025
57355	EN 10025-3	5355N	Std. 0.20	0.90-1.65	0.50	0.030	0.025	0.05	0.12	0.05	0.10	0.30	0.50	0.55	0.02	0.015

Mechanical Properties

Çolakoğlu Quality ID	Standard	Quality	Re		Rm ⁽¹⁾	A(%)	Impact (long.) ²		Bending (trans., ≤180°)	
			N/mm ²	min.			Temp.	KVc	mrB	
			d : thickness, mm		N/mm ²	d : thickness, mm	°C	J	thickness, d (mm)	
			≤16	16 < d ≤40						
52420	EN 10025-3	5420N-Special (SAH540)	420	400	520-680	19	-20	40	4d	
52460	EN 10025-3	5460N	460	440	540-720	17	-20	40	4d	
57355	EN 10025-3	5355N	355	345	470-630	22	-20	40	4d	

ATMOSPHERE CORROSION RESISTANT STEELS

Standard: EN 10025 Part 5 - 2004

Chemical Composition (%)

Çolakoglu Quality ID	Standard	Quality	C	Mn	Si	P	S	Cr	Ni	Cu	Al	N
58235	EN 10025-5	S235J0W	Std.	0.16	0.15-0.70	0.45	0.040	0.35-0.85	—	0.20-0.60	—	0.01
58236	EN 10025-5	S235J2W	Std.	0.16	0.15-0.70	0.45	0.035	0.35-0.85	—	0.20-0.60	—	0.01
58355	EN 10025-5	S355J0W	Std.	0.19	0.45-1.60	0.55	0.040	0.35-0.85	—	0.20-0.60	—	0.01
58356	EN 10025-5	S355J2W	Std.	0.19	0.45-1.60	0.55	0.035	0.35-0.85	—	0.20-0.60	—	0.01
58357	EN 10025-5	S355J0WP	Std.	0.15	1.1	0.80	0.05-0.16	0.040	0.25-1.35	—	0.20-0.60	0.01
58358	EN 10025-5	S355J2WP	Std.	0.15	1.1	0.80	0.05-0.16	0.035	0.25-1.35	—	0.20-0.60	0.01

Mechanical Properties

Çolakoglu Quality ID	Standard	Quality	Re		N/mm ²	Rm ¹⁾		A (%)			Impact (long. ²⁾	
			min.	min.		d : thickness, mm	d : thickness, mm	A ₈₀	A ₅	Temp. min.	KJc	
												≤16
58235	EN 10025-5	S235J0W	235	225	360-510	360-510	19	20	21	26	0	27 ³⁾
58236	EN 10025-5	S235J2W	235	225	360-510	360-510	17	18	19	24	-20	27 ³⁾
58355	EN 10025-5	S355J0W	355	345	510-680	470-630	16	17	18	22	0	27 ³⁾
58356	EN 10025-5	S355J2W	355	345	510-680	470-630	14	15	16	20	-20	27 ³⁾
58357	EN 10025-5	S355J0WP	355	345	510-680	470-630	16	17	18	22	0	27 ³⁾
58358	EN 10025-5	S355J2WP	355	345	510-680	470-630	14	15	16	20	-20	27 ³⁾

Explanations

- 1) Tensile tests are applied to "Transversal" test samples.
- 2) Impact tests are applied to "longitudinal" test samples.
- 3) Impact tests are carried out if it is customer's request in order.

WHEEL STEELS SUITABLE FOR COLD FORMING, BENDING AND SPINNING

Standard: EN 10025-Part 2-2004

Chemical Composition (%)

Çolakoğlu Quality ID	Standard	Quality	C		Mn		Si		P		S		Cu		Cr+Cr+Ni		Al		N		Ca		
			max.	min.	max.	min.	max.	min.	max.	min.	max.	min.	max.	min.	max.	min.	max.	min.	max.	min.	max.	min.	max.
82235	EN 10025-2	S235JRC Special	Std.	0.14	0.7	0.15	0.02	0.01	"1"	0.30	0.02-0.045	0.001	—	—	—	—	—	—	—	—	—	—	—
81235	EN 10025-2	S235J2C+N	Std.	0.14	0.7	0.1	0.02	0.015	"1"	0.30	0.02-0.07	0.009	—	—	—	—	—	—	—	—	—	—	—
82280	EN 10025-2	S275JRC	Std.	0.10	0.8	0.05	0.02	0.015	"1"	0.30	0.015-0.07	0.009	—	—	—	—	—	—	—	—	—	—	—
82290	EN 10025-2	S275JRC Special (S275J2C+N)	Std.	0.18	1.25	0.1	0.020	0.015	"1"	0.30	0.02-0.07	0.009	—	—	—	—	—	—	—	—	—	—	—
82330 ²⁾	EN 10025-2	S355JRC Special (S355J2C+N)	Std.	0.15-0.18	1.3-1.4	0.1	0.02	0.01	0.15	—	0.02-0.06	0.001	20-50	—	—	—	—	—	—	—	—	—	—
82355	EN 10025-2	S355J2C+N Special	Std.	0.24	1.6	0.55	0.035	0.035	0.55	—	—	0.012	—	—	—	—	—	—	—	—	—	—	—
81330	EN 10025-2	S355JRC Special	Std.	0.19	1.6	0.3	0.025	0.02	"2"	0.30	0.02-0.07	0.009	—	—	—	—	—	—	—	—	—	—	—
80235	EN 10025-2	S235JRP-Special S5092 Rev 27	Std.	0.06-0.16	0.40-0.90	0.015-0.1	0.025	0.015	—	—	0.020-0.06	—	—	—	—	—	—	—	—	—	—	—	—
80236	EN 10025-2	S235JRP-Special S5095 Rev 4	Std.	0.06-0.16	0.40-0.90	0.015-0.1	0.025	0.015	—	—	0.020-0.06	—	—	—	—	—	—	—	—	—	—	—	—
80280	EN 10025-2	S275JRP-Special	Std.	0.21	1.6	—	0.05	0.05	—	—	—	—	—	—	—	—	—	—	—	—	—	—	—
80290	EN 10025-2	S275J2+N-Special	Std.	0.21	1.6	—	0.05	0.05	—	—	—	—	—	—	—	—	—	—	—	—	—	—	—
80355	EN 10025-2	S355JRP-Special	Std.	0.23	1.7	0.6	0.05	0.05	—	—	—	—	—	—	—	—	—	—	—	—	—	—	—

Explanations

1) Ceq is calculated by %CE (IWI) = C+Mn/6+(Cr+Mo+V)/5+(Ni+Cu)/15 formula.

2) Cr+Cr+Ni is permitted up to a maximum 0.3 %.

3) Cr max. 0.05 %, Mo max. 0.015 %, V max. 0.005 %, Ni max. 0.1 %, Nb max. 0.005 %.

WHEEL STEELS SUITABLE FOR COLD FORMING, BENDING & SPINNING

Standard: EN 10025-Part2-2004

		Mechanical Properties									
Çelikloglu Quality ID	Standard	Quality	Re	Rm ⁽¹⁾	A(%)	Bending		Impact (long.) ⁽²⁾			
			N/mm ²	min.	A _s	Ø	Temp.	KVc			
			min.	min.	min.	d: kalınlık	°C	J			
82235	EN 10025-2	S235JRC Special	235	360-440	30	0.5d	+20	27 ⁽³⁾			
81235	EN 10025-2	S235J2C+N	235-320	350-430	35	0.5d	-20	27 ⁽³⁾			
82280	EN 10025-2	S275JRC	280-350	390-460	28	0.5d	+20	27 ⁽³⁾			
82290	EN 10025-2	S275JRC Special (S275J2C+N)	280-420	420-500	29	0.5d	+20	27 ⁽³⁾			
82230	EN 10025-2	S355JRC Special (S355J2C+N)	330-450	480-590	25	2.0d	+20	27 ⁽³⁾			
82355	EN 10025-2	S355J2C+N Special	330-540	480-600	24	2.0d	-20	27 ⁽³⁾			
81330	EN 10025-2	S355JRC Special	330-540	480-600	24	2.0d	+20	27 ⁽³⁾			
80235	EN 10025-2	S235JRC Special S5092 Rev 27	230	370-450	30	0.5d	-	-			
80236	EN 10025-2	S235JRC Special S5095 Rev 4	230	370-450	30	0.5d	-	-			
80280	EN 10025-2	S275J0-Special	275	410-560	24	-	0	27			
80290	EN 10025-2	S275J2+N-Special	275	410-560	24	-	0	27			
80355	EN 10025-2	S355J0-Special	355	470-630	24	-	0	27			

Explanations

- 1) Tensile tests are applied to "Transversal" test samples.
- 2) Impact tests are not carried out if nominal thickness is lesser than 6 mm.
- 3) Impact tests are carried out if it is customer's request in order.

		Mechanical Properties																
Çelikloglu Quality ID	Standard	Quality	Bending ⁽¹⁾ (trans., ≤90°, mrb)															
			thickness, d (mm)															
			1<d≤15	1,5<d≤2,5	2,5<d≤3	3<d≤4	4<d≤5	5<d≤6	6<d≤7	7<d≤8	8<d≤10	10<d≤12	12<d≤14	14<d≤16	16<d≤18	18<d≤20	20<d≤25	25<d≤30
82235	EN 10025-2	S235JRC Special	1.6	2.5	3	5	6	8	10	12	16	20	25	28	36	40	50	60
82280	EN 10025-2	S275JRC	2	3	4	5	8	10	12	16	20	25	28	32	40	45	55	70
82290	EN 10025-2	S275JRC Special (S275J2C+N)	2	3	4	5	8	10	12	16	20	25	28	32	40	45	55	70

WHEEL STEELS SUITABLE FOR COLD FORMING, BENDING AND SPINNING

Standard: EN 10111:2008-06

Chemical Composition (%)

Colakoglu Quality ID	Standard	Quality	Std.	C	Mn	Si	P	S	Cu	Al
				max.	max.	max.	max.	max.	max.	min.
81222	EN 10111	DD11	Std.	0.10	0.45	-	0.035	0.035	—	—
80122	EN 10111	DD 11-Special-1	Std.	0.10	0.50	0.20	0.035	0.030	0.20	0.010
80222	EN 10111	DD 11-Special-2	Std.	0.14	0.65	-	0.050	0.050	—	—

Mechanical Properties

Colakoglu Quality ID	Standard	Quality	Re		Rm ⁽¹⁾	A(%)
			N/mm ²			A ₅
			min.	min.	min.	min.
80122	EN 10111	DD 11-Special-1	215		300-440	35
80222	EN 10111	DD 11-Special-2	340		440	28

HIGH STRENGTH WHEEL STEELS SUITABLE FOR COLD FORMING AND SPINNING

Standard: EN 10149-Part2-1995

Chemical Composition (%)

Colakoglu Quality ID	Std.	Quality	Std.	C	Mn	Si	P	S	Al	Nb ⁽¹⁾	V ⁽¹⁾	Ti ⁽¹⁾
				max.	max.	max.	max.	max.	min.	max.	max.	max.
83355	EN 10149-2	S355MC	Std.	0.12	1.50	0.50	0.025	0.020	0.015	0.09	0.20	0.15
84355	EN 10149-2	S355MC-Special S5088 Rev 10	Std.	0.12	1.50	0.50	0.025	0.010	0.020	0.09	0.20	0.15
83420	EN 10149-2	S420MC (HL-2242-01)	Std.	0.12	1.60	0.50	0.025	0.015	0.015	0.09	0.20	0.15
83460	EN 10149-2	S460MC (HL-6000-02)	Std.	0.12	1.60	0.50	0.025	0.015	0.015	0.09	0.20	0.15

Explanations

1) Nb+V+Ti = % 0.22 max.

Mechanical Properties

Colakoglu Quality ID	Std.	Quality	Re ⁽¹⁾	Rm ⁽¹⁾	A(%)		Impact (long.) ⁽²⁾		Bending
			N/mm ²		A ₈₀	A ₅	Temp.	KVc	(tran.;180°)
					d<3	d≤T		min.	mdb
			min.	min.	min.	min.	°C	J	(d=thickness)
83355	EN 10149-2	S355MC	355	430-550	19	23	-20	40	0.5d
84355	EN 10149-2	S355MC-Special S5088 Rev 10	340-430	470-560	25	-	-40	27	0.5d
83420	EN 10149-2	S420MC (HL-2242-01)	420	480-620	16	19	-20	40	0.5d
83460	EN 10149-2	S460MC (HL-6000-02)	450-550	550-650	-	22	-	-	1d

Explanations

1) Tensile tests are applied to "Longitudinal" test samples.

2) Impact tests are carried out if it is customer's request in order. Impact tests are not carried out if nominal thickness is lesser than 6 mm.

3) Bending test values are applied to "Transversal" test samples.

HIGH STRENGTH DUAL PHASE STEELS SUITABLE FOR COLD FORMING

Standard : EN10338-2009

Chemical Composition (%)

Colakoglu Quality ID	Standard	Quality	Std.	C	Mn	Si	P	S	Al	Mo	Nb	N ppm	Cu	Cr
				max.	max.	max.	max.	max.	min.	max.	max.	max.	max.	max.
83500	EN 10338	HCT500X (DP 500)	Std.	0.06-0.08	1.10-1.20	0.20-0.30	0.020	0.005	0.030-0.060	0.05	0.005	100	0.15-0.20	0.10-0.20

Explanations

1) The values are applied to strips with thickness $T \leq 6$ mm

HIGH STRENGTH DUAL PHASE WHEEL STEEL SUITABLE FOR COLD FORMING AND SPINNING

Standard: EN 10338-2010

Chemical Composition (%)

Colakoglu Quality ID	Standard	Quality	Std.	C	Mn	Si	P	S	Al	Mo+Cr	V	Nb+Ti	B ppm	Cu	Cr
				max.	max.	max.	max.	max.	min.	max.	max.	max.	max.	max.	max.
83600	EN 10338	HDT580X (DP 600)	Std.	0.17	2.20	0.80	0.080	0.015	2.0	1.00	0.20	0.15	50	-	-

Explanations

1) The values are applied to strips with thickness $T \leq 6$ mm

Mechanical Properties

Colakoglu Quality ID	Standard	Quality	Re ⁽¹⁾	Rm ⁽¹⁾	A(%)	Strain hardening exponent
			N/mm ²		A ₅₀	n
			min.	min.	min.	min.
83600	EN 10338-2010	HDT580X (DP 600)	330-480	580	19	0.13

Explanations

1) Tensile tests are applied to "Transversal" test samples.

HOT ROLLED HIGH STRENGTH DUAL PHASE STEEL SUITABLE FOR COLD FORMING

Standard : EN 10338-2010

Chemical Composition (%)

Colakoglu Quality ID	Standard	Quality	Std.	C	Mn	Si	P	S	Al
				max.	max.	max.	max.	max.	min.
83610	EN 10338	HCT600X (DP 600)	Std.	0.07-0.1	1.30-1.45	0.20-0.30	0.020	0.008	0.025-0.06
83780	EN 10338	HCT780X (DP 780)	Std.	0.09-0.11	1.70-1.90	0.20-0.30	0.020	0.005	0.03-0.06

Chemical Composition (%)

Colakoglu Quality ID	Standard	Quality	Std.	Mo+Cr	V	Nb+Ti	B ppm	Cu	Cr
				max.	max.	max.	max.	max.	max.
83610	EN 10338	HCT600X (DP 600)	Std.	0.75	0.01	0.020	100	0.15-0.20	0.50-0.70
83780	EN 10338	HCT780X (DP 780)	Std.	-	-	-	5	0.10-0.20	0.20-0.30

Explanations

1) The values are applied to strips with thickness $T \leq 6$ mm

SPIRAL PIPE STEEL										
Standard: EN 10025-Part 2-2004										
Chemical Composition (%)										
Çolakoğlu Quality ID	Std.	Quality	C		Mn	Si	P	S	Cu	%N
			max.	0.24	max.	max.	max.	max.	max.	max.
92355	EN 10025-2	S355JR-Special	Std.	0.24	1.60	0.55	0.035	0.035	0.55	0.012

Mechanical Properties											
Çolakoğlu Quality ID	Std.	Quality	Re		Rm		A (%)		Impact (long.)		
			min.	max.	N/mm ²	d : thickness, mm	A _{5g}	A5	Temp.	KVc min.	
92355	EN 10025-2	S355JR-Special	≤16	16 < d ≤ 40	< 3	3 < d < 100	1.5 < d ≤ 2	2 < d ≤ 2.5	2.5 < d ≤ 3	3 < d ≤ 40	J
			355	345	510-680	470-630	16	17	18	22	+20

BOILER STEELS

Standard: EN 10028 - Part 2 - 2008

Chemical Composition (%)

Colakoglu Quality ID	Standard	Quality	Std.	C	Si	Mn	P	S	Al	Nb	Cr ⁽¹⁾	Cu ⁽¹⁾	Mo ⁽¹⁾	Ni ⁽¹⁾
				max.	max.	max.	max.	max.	min.	max.	max.	max.	max.	max.
86235 ⁽²⁾	EN 10028-2	P235GH	Std.	0.16	0.35	0.60 - 1.20	0.025	0.020	0.020	0.020	0.30	0.30	0.08	0.30
86265 ⁽²⁾	EN 10028-2	P265GH	Std.	0.20	0.40	0.80 - 1.20	0.025	0.020	0.020	0.020	0.30	0.30	0.08	0.30
86295 ⁽²⁾	EN 10028-2	P295GH	Std.	0.08 - 0.20	0.40	0.90 - 1.50	0.025	0.015	0.020	0.020	0.30	0.30	0.08	0.30
86355	EN 10028-2	P355GH	Std.	0.10 - 0.22	0.60	1.10 - 1.70	0.025	0.015	0.020	0.020	0.30	0.30	0.08	0.30

Explanations

- 1) Cr+Cu+Mo+Ni ≤ % 0.70
- 2) Mn content can be decreased as 0.20 % if the thickness is under 6 mm.

Mechanical Properties

Colakoglu Quality ID	Standard	Quality	Re (min.)		Rm ⁽¹⁾	A ₅ (%)	Impact ⁽²⁾ (tran.)		Rp 0.02 ⁽¹⁾ (min.) T: 300°C	
			N/mm ²		N/mm ²	min.	Temp.	KVc (min.)	N/mm ² (kg / mm ²)	
			d ≤ 16	16 < d ≤ 40			°C	J	d ≤ 16	16 < d ≤ 40
86235	EN 10028	P235GH	235	225	360 - 480	24	-20	27	153	147
86265	EN 10028	P265GH	265	255	410 - 530	22	-20	27	173	166
86295	EN 10028	P295GH	295	290	460 - 580	22	-20	27	192	189
86355	EN 10028	P355GH	355	345	510 - 650	20	-20	27	232	225

Explanations

- 1) Tensile tests are applied to "Transversal" test samples.
- 2) Impact tests are not carried out if nominal thickness is lesser than 6 mm.

BOILER STEELS

Standard: EN 10028 - Part 3 - 2008

Chemical Composition (%)

Colakoglu Quality ID	Standard	Quality	Std.	C	Si	Mn	P	S	Al	Cr	Ni	Cu	Mo	V	Ti	Nb
				max.	max.	max.	max.	max.	min.	max.	max.	max.	max.	max.	max.	max.
87355	EN 10028 Part 3	P355NL1	Std.	0.18	0.50	1.10-1.70	0.025	0.010	0.02	0.30	0.50	0.30	0.08	0.1	0.03	0.05

Explanations

- 1) Mn content could be 0.60 % if the thickness is less than 6 mm.

Mechanical Properties

Colakoglu Quality ID	Standard	Quality	Re (min.)		Rm ⁽¹⁾	A ₅ (%)	Impact ⁽²⁾ (tran.)		Rp 0.02 ⁽¹⁾ (min.) T: 300°C
			N/mm ²		N/mm ²	min.	Temp.	KVc (min.)	N/mm ² (kg / mm ²)
			d ≤ 16				°C	J	d ≤ 16
87355	EN 10028-Part 3	P355NL1	355		490-630	22	-40	27	232

STEELS SUITABLE TO USE UNDER LOW PRESSURE

Standard: EN 10207-2005

Chemical Composition (%)

Colakoglu Quality ID	Standard	Quality	Std.	C	Si	Mn	P	S	Al
				max.	max.	max.	max.	max.	min.
86275	EN 10207	P275SL	Std.	0.16	0.40	0.50-1.50	0.025	0.020	0.02

Explanations

1) If the chemical composition includes Nb, V, Ti, %Al min. value does not valid.

Mechanical Properties

Colakoglu Quality ID	Std.	Quality	Re ⁽¹⁾			Rm ⁽¹⁾	A (%)		Impact (long.) ²	
			N/mm ²			N/mm ²	l	t	Temp.	KVC min.
			min.	min.	min.					
			d ≤ 16	16 < d ≤ 40	40 < d ≤ 60					
86275	EN 10207	P275SL	275	265	255	390-510	17	18	-50	28

BOILER PIPE STEELS

Standard: EN 10217-2-2002

Chemical Composition (%)

Colakoglu Quality ID	Standard	Quality	Std.	C	Si	Mn	P	S	Al	Cr ⁽¹⁾	Cu ⁽¹⁾	Mo ⁽¹⁾	Nb ⁽¹⁾	V	Ti
				max.	max.	max.	max.	max.	min.	max.	max.	max.	max.	max.	max.
86435	EN 10217-2	P235GH-low Si	Std.	0.16	0.35	1.20	0.025	0.020	0.020	0.30	0.30	0.08	0.010	0.020	0.030

Explanations

1) Cr+Cu+Mo+Ni ≤ % 0.70.

Mechanical Properties

Colakoglu Quality ID	Std.	Quality	Re ⁽¹⁾	Rm ⁽¹⁾	A (%)		Impact (long.) ²		Impact (tran.) ³	
			N/mm ²	N/mm ²	l	t	Temp.	KVC min.	Temp.	KVC min.
			min.	min.						
			d ≤ 16	16 < d ≤ 40	40 < d ≤ 60					
86435	EN 10217-2	P235GH-low Si	235	360-500	25	23	0	40	0	27

Explanations

1) Tensile tests are applied to "Transversal" test samples.

2) Impact test values are valid upto ≤16 mm in thickness. Impact tests can be carried out in transversal and longitudinal directions of coils.

3) l: longitudinal, t: transversal.

BOILER PIPE STEELS

Standard : EN 10217-3-2005

Chemical Composition (%)

Colakoglu Quality ID	Standard	Quality		C	Si	Mn	P	S	Al	Cr	Cu	Mo	Nb	V	Ti
				max.	max.	max.	max.	max.	min.	max.	max.	max.	max.	max.	max.
86475	EN 10217-3	P275NL1-low Si	Std.	0.16	0.40	0.50-1.50	0.025	0.020	0.02	0.30	0.30	0.08	0.05	0.05	0.03

Mechanical Properties

Colakoglu Quality ID	Standard	Quality	Re ⁽¹⁾	Rm ⁽¹⁾	A (%)		Impact (long.) ²		Impact (tran.) ²	
			N/mm ²	N/mm ²	l	t	Temp.	KVc	Temp.	KVc
			min.	min.	min.	min.	°C	J	°C	J
86475	EN 10217-3	P275NL1-low Si	275	390-530	24	22	-40	40	-40	27

LPG TUBE STEELS

Standard: EN 10120-2008

Chemical Composition (%)

Colakoglu Quality ID	Standard	Quality		C	Si	Mn	P	S	Al	N ⁽¹⁾	Nb	Ti
				max.	max.	min.	max.	max.	min.	max.	max.	max.
85245	EN 10120	P245NB	Std.	0.16	0.25	0.30	0.025	0.015	0.020	0.009	0.050	0.03
85265	EN 10120	P265NB	Std.	0.19	0.25	0.40	0.025	0.015	0.020	0.009	0.050	0.03
85310	EN 10120	P310NB	Std.	0.20	0.50	0.70	0.025	0.015	0.020	0.009	0.050	0.03
85355	EN 10120	P355NB	Std.	0.20	0.50	0.70	0.025	0.015	0.020	0.009	0.050	0.03

Explanations

1) N content can be % 0.012 if (Al/N) ≥ 2.2 or steel includes Nb and Ti additions.

Mechanical Properties

Colakoglu Quality ID	Standard	Quality	Re	Rm ⁽¹⁾	A(%)	
			N/mm ²	N/mm ²	A ₁₀ (min.)	A ₅ (min.)
			(min.)		d < 3	3 ≤ d ≤ 5
85245	EN 10120	P245NB	245	360 - 450	26	34
85265	EN 10120	P265NB	265	410 - 500	24	32
85310	EN 10120	P310NB	310	460 - 550	21	28
85355	EN 10120	P355NB	355	510 - 620	19	24

Explanations

1) Tensile tests are applied to "Transversal" test samples.

GENERAL STRUCTURAL STEELS SUITABLE FOR HEAT TREATMENT

Standard: EN 10083 - Part 2 -2006

Chemical Composition (%)

Colakoglu Quality ID	Standard	Quality		C	Mn	Si	P	S	Cr	Ni	Mo	Cr+Mo+Ni
				max.	max.	max.	max.	max.	max.	max.	max.	
98628	EN 10083-2	28Mn6	Std.	0.25-0.32	1.30-1.65	0.40	0.030	0.010	0.40	0.40	0.10	0.63
98035	EN 10083-2	C35E	Std.	0.32-0.39	0.5-0.8	0.40	0.030	0.030	0.40	0.40	0.10	0.63
98135	EN 10083-2	C35E-Cr	Std.	0.32-0.39	0.5-0.8	0.40	0.030	0.030	0.40	0.40	0.10	0.63
98145	EN 10083-2	C45E-Special	Std.	0.42-0.50	0.5-0.8	0.40	0.030	0.030	0.40	0.40	0.10	0.63
98060	EN 10083-2	C60E	Std.	0.57-0.65	0.6-0.9	0.40	0.030	0.030	0.40	0.40	0.10	0.63
98160	EN 10083-2	C60E-Special	Std.	0.57-0.65	0.6-0.9	0.40	0.030	0.030	0.40	0.40	0.10	0.63
98260	EN 10083-2	C60E-1-Cr	Std.	0.57-0.65	0.6-0.9	0.40	0.030	0.030	0.20-0.40	0.40	0.10	0.63

Explanations

1) There is no mechanical test guarantee for heat treatment steels.

GENERAL STRUCTURAL STEELS SUITABLE FOR HEAT TREATMENT

Standard: EN 10083- Part 3 -2006

Chemical Composition (%)

Colakoglu Quality ID	Standard	Quality		C	Mn	Si	P	S	B	Cr
				max.	max.	max.	max.	max.	ppm	max.
98530	EN 10083-3	30MnB5	Std.	0.27-0.33	1.15-1.45	0.40	0.035	0.040	8-50	-
98534	EN 10083-3	34MnB5	Std.	0.33-0.37	1.15-1.45	0.40	0.035	0.040	8-50	-
98527	EN 10083-3	27MnCrB5-2	Std.	0.24-0.30	1.10-1.40	0.40	0.035	0.040	8-50	0.30-0.60
98526	EN 10083-3	26MnB5	Std.	0.27-0.33	1.15-1.45	0.40	0.035	0.040	8-50	-
98522	EN 10083-3	22MnB5	Std.	0.18-0.23	1.15-1.45	0.40	0.035	0.040	8-50	-

Explanations

1) There is no mechanical test guarantee for heat treatment steels.

HIGH STRENGTH STEELS SUITABLE FOR COLD FORMING AND BENDING

Standard: EN 10149 - Part2 - 1995

Chemical Composition (%)

Colakoglu Quality ID	Standard	Quality		C	Mn	Si	P	S	Al	V ²⁾	Ti ²⁾	Nb ²⁾	Mo	B
				max.	max.	max.	max.	max.	min.	max.	max.	max.	max.	max.
36315	EN 10149-2	S315MC	Std.	0.12	1.30	0.50	0.025	0.020	0.015	0.20	0.15	0.09	-	-
36355	EN 10149-2	S355MC	Std.	0.12	1.50	0.50	0.025	0.020	0.015	0.20	0.15	0.09	-	-
36356	EN 10149-2	S355MC-Special	Std.	0.12	1.50	0.50	0.025	0.020	0.015	0.20	0.15	0.09	-	-
36420	EN 10149-2	S420MC	Std.	0.12	1.60	0.50	0.025	0.015	0.015	0.20	0.15	0.09	-	-
36421	EN 10149-3	S420MC-with Si	Std.	0.12	1.60	0.50	0.025	0.015	0.015	0.20	0.15	0.09	-	-
36460	EN 10149-2	S460MC	Std.	0.12	1.60	0.50	0.025	0.015	0.015	0.20	0.15	0.09	-	-
36461	EN 10149-5	S460MC-with Si	Std.	0.12	1.60	0.50	0.025	0.015	0.015	0.20	0.15	0.09	-	-
36500	EN 10149-2	S500MC	Std.	0.12	1.70	0.50	0.025	0.015	0.015	0.20	0.15	0.09	-	-
36501	EN 10149-2	S500MC-with Si	Std.	0.12	1.70	0.50	0.025	0.015	0.015	0.20	0.15	0.09	-	-
36550	EN 10149-2	S550MC	Std.	0.12	1.80	0.50	0.025	0.015	0.015	0.20	0.15	0.09	-	-
36551	EN 10149-2	S550MC-with Si	Std.	0.12	1.80	0.50	0.025	0.015	0.015	0.20	0.15	0.09	-	-
36600	EN 10149-2	S600MC	Std.	0.12	1.90	0.50	0.025	0.015	0.015	0.20	0.15	0.09	0.5	50
36650	EN 10149-2	S650MC	Std.	0.12	2.00	0.60	0.025	0.015	0.015	0.20	0.22	0.09	0.5	50
36700	EN 10149-2	S700MC	Std.	0.12	2.10	0.60	0.025	0.015	0.015	0.20	0.22	0.09	0.5	50

Explanations

- 1) All grades are produced by thermo mechanical rolling method.
- 2) Nb+Ti+V ≤ % 0,22

Mechanical Properties

Colakoglu Quality ID	Standard	Quality	Re	Rm ¹⁾	A(%)		Impact ²⁾ KJc (long.)	Bending (tran.;180°)
					d<3	d≥ 3		
			N/mm ²		A ₅₀	A ₅	Temp. -20°C	mdb
			min.	min.	min.	min.	min.	d: thickness
36315	EN 10149-2	S315MC	315	390 - 510	20	24	40 J	0
36355	EN 10149-2	S355MC	355	430 - 550	19	23	40 J	0.5 d
36356	EN 10149-2	S355MC-Special	355	430 - 550	19	23	40 J	0.5 d
36420	EN 10149-2	S420MC	420	480 - 620	16	19	40 J	0.5 d
36421	EN 10149-3	S420MC-with Si	420	480 - 620	16	19	40 J	0.5 d
36460	EN 10149-2	S460MC	460	520 - 670	14	17	40 J	1 d
36461	EN 10149-5	S460MC-with Si	460	520 - 670	14	17	40 J	1 d
36500	EN 10149-2	S500MC	500	550 - 700	12	14	40 J	1 d
36501	EN 10149-2	S500MC-with Si	500	550 - 700	12	14	40 J	1 d
36550	EN 10149-2	S550MC	550	600 - 760	12	14	40 J	1.5 d
36551	EN 10149-2	S550MC-with Si	550	600 - 760	12	14	40 J	1.5 d
36600	EN 10149-2	S600MC	600	650-820	11	13	40 J	1.5 d
36650	EN 10149-2	S650MC	650	700-880	10	12	40 J	2d
36700	EN 10149-2	S700MC	700	750-950	10	12	40 J	2d

Explanations

- 1) Tensile tests are applied to "Longitudinal" test samples.
- 2) Impact tests are not carried out if nominal thickness is lesser than 6 mm.

MICRO ALLOYED STEELS SUITABLE FOR COLD FORMING AND GALVANIZING

Standard: EN 10025-Part 2-2004

Chemical Composition (%)

Çolakoğlu Quality ID	Standard	Quality	C	Mn	Si	P	S	Cu	Cr	Ni	Al	V	Ti	Nb	N
44277	EN 10025-2	S275JR-Special	Std. 0.03 - 0.05	0.3 - 0.5	0.03	0.015	0.008	0.20	0.10	0.10	0.02 - 0.06	0.2	0.005	0.01 - 0.02	0.01

Mechanical Properties

Çolakoğlu Quality ID	Standard	Quality	Re		Rm		Hardness	
			N/mm ²		N/mm ²		HB	
44277	EN 10025-2	S275JR-Special	275 - 365		410 - 485			115 - 145

MICRO ALLOYED STEELS SUITABLE FOR COLD FORMING AND GALVANIZING

Standard: EN 10149-Part2-1995

Chemical Composition (%)

Colakoglu Quality ID	Standard	Quality		C	Mn	Si	P	S	Al	V ⁽²⁾	Ti ⁽²⁾	Nb ⁽²⁾
				max.	max.	max.	max.	max.	min.	max.	max.	max.
37280	EN 10149-2	S280MC-Special	Std.	0.12	1.30	0.50	0.025	0.020	0.015	0.2	0.15	0.09
37315	EN 10149-2	S315MC	Std.	0.12	1.30	0.50	0.025	0.020	0.015	0.20	0.15	0.09
37355	EN 10149-2	S355MC	Std.	0.12	1.50	0.50	0.025	0.020	0.015	0.20	0.15	0.09
37420	EN 10149-2	S420MC	Std.	0.12	1.60	0.50	0.025	0.015	0.015	0.20	0.15	0.09
37421	EN 10149-2	S420MC-HX-420LAD	Std.	0.12	1.60	0.50	0.025	0.015	0.015	0.20	0.15	0.09
37460	EN 10149-2	S460MC	Std.	0.12	1.60	0.50	0.025	0.015	0.015	0.20	0.15	0.09
37352	EN 10149-2	S355MC-Special	Std.	0.06 - 0.08	0.45 - 0.65	0.15	0.020	0.003	0.20 - 0.60	-	0.10 - 0.20	0.25 - 0.35
37422	EN 10149-2	S420MC-Special	Std.	0.06 - 0.09	0.60 - 0.70	0.08	0.015	0.005	0.20 - 0.70	-	0.10 - 0.20	0.40 - 0.50
37462	EN 10149-2	S460MC-Special	Std.	0.07 - 0.08	1.00 - 1.20	0.08	0.015	0.003	0.20 - 0.70	-	0.15 - 0.30	0.45 - 0.60

Explanations

- 1) All grades are produced by thermo mechanical rolling method.
2) Nb+Ti+V ≤ % 0,22

Mechanical Properties

Colakoglu Quality ID	Standard	Quality	Re	Rm ⁽¹⁾	A(%)		Impact ⁽²⁾	Bending
					d<3	d≥ 3		
			N/mm ²		A ₃₀	A ₅	Temp. =20°C	mdb
			min.	min.	min.	min.		
37315	EN 10149-2	S315MC	315	390 - 510	20	24	40 J	0
37355	EN 10149-2	S355MC	355	430 - 550	19	23	40 J	0.5 d
37420	EN 10149-2	S420MC	420	480 - 620	16	19	40 J	0.5 d
37421	EN 10149-2	S420MC-HX420LAD	420	480 - 620	16	19	40 J	0.5 d
37460	EN 10149-2	S460MC	420	480 - 620	16	19	40 J	1 d

Explanations

- 1) Tensile tests are applied to "Longitudinal" test samples.
2) Impact tests are not carried out if nominal thickness is lesser than 6 mm.

NORMALISE ROLLED STEELS SUITABLE FOR COLD FORMING

Standard: BS 10149-Part 3-2013

Chemical Composition (%)

Çolakoglu Quality ID	Standard	Quality	Std.	C	Mn	Si	P	S	V	Ti	Al	Nb
				max.	max.	max.	max.	max.	max.	max.	max.	max.
38280	BS 10149-3	S280NC-Special	Std.	0.16	1.20	0.50	0.025	0.020	0.10	0.15	0.015	0.09

Mechanical Properties

Çolakoglu Quality ID	Standard	Quality	Re		Rm	A(%)		Bending	
			N/mm ²			d<3	d≥3	tran., 180°	
						A ₅₀	A ₅	mdb	
			min.	min.	max.	min.	min.	d: thickness	
38280	BS 10149-3	S280NC-Special	280	370	490	24	30	0	

PRESSURE PIPE STEELS

Standard: EN 10217 Part 1-2005

Chemical Composition (%)

Çolakoglu Quality ID	Standard	Quality	Std.	C	Mn	Si	P	S	Cr	Ni	Al	Cu	Mo
				max.	max.	max.	max.	max.	max.	max.	max.	max.	max.
94235	EN 10217-1	P235TR1	Std.	0.16	1.20	0.35	0.025	0.020	0.30	0.30	-	0.30	0.08
94236	EN 10217-1	P235TR2	Std.	0.16	1.20	0.35	0.025	0.020	0.30	0.30	0.02	0.30	0.08
94035	EN 10217-1	P235TR1-low Si	Std.	0.16	1.20	0.35	0.025	0.020	0.30	0.30	-	0.30	0.08
94036	EN 10217-1	P235TR2-low Si	Std.	0.16	1.20	0.35	0.025	0.020	0.30	0.30	0.02	0.30	0.08

Explanations

1) Cu+Cr+Mo+Ni = 0.70 max

Mechanical Properties

Çolakoglu Quality ID	Standard	Quality	Re ⁽¹⁾		Rm ⁽¹⁾	A(%)		Impact (long.) ⁽²⁾ min.					
			N/mm ²					Temp.	KVc	Temp.	KVc	Temp.	KVc
			d≤16	16<d≤40		l	t						
			min.	min.	min.	min.	min.	°C	J	°C	J	°C	J
94235	EN 10217-1	P235TR1	235	225	360-500	25	23	0	-	-10	-	0	-
94236	EN 10217-1	P235TR2	235	225	360-500	25	23	0	40	-10	28	0	27
94035	EN 10217-1	P235TR1-low Si	235	225	360-500	25	23	0	-	-10	-	0	-
94036	EN 10217-1	P235TR2-low Si	235	225	360-500	25	23	0	40	-10	28	0	27

Explanations

1) Tensile tests are applied to "Transversal" test samples.

2) Impact tests are applied to "Transversal" and "Longitudinal" test samples.

**LOW ALLOYED GENERAL STRUCTURAL STEELS SUITABLE FOR COLD DRAWING AND NORMALIZING
(SUITABLE FOR CLASS 1 GALVANIZING Std.)**

Standard: EN 10025 Part 2-2004

Chemical Composition (%)

Colakoglu Quality ID	Standard	Quality		C	Mn	Si	P	S	Cu	Ti	N ppm	Nb	Ceq
				max.	max.	max.	max.	max.	max.	max.	max.	max.	max.
54510	EN 10025-2	S355JR+N-low Si (Fe510DTCL)	Std.	0.24	1.60	0.55	0.035	0.035	0.55	0.01-0.03	120	0.005-0.03	0.45

Explanations

- 1) The maximum value for nitrogen does not apply if the chemical composition shows a minimum aluminium content of 0.020 %.
- 2) Ceq is calculated by %CE (IIW) = C+Mn/6+(C+Mo+V)/5+(Ni+Cr)/15 formula.

Mechanical Properties

Colakoglu Quality ID	Std.	Quality	Re		Rm ⁽²⁾		A(%, min.)					Impact (long.) ⁽³⁾	
			N/mm ²		N/mm ²		A ₉₀			A ₅		Temp.	KVc
			min.	min.	d : thickness, mm		d : thickness, mm						
			d : thickness, mm		d : thickness, mm		d : thickness, mm		d : thickness, mm				
			≤16	16<d≤40	<3	3≤d<40	1<d≤1.5	1.5<d≤2	2<d≤2.5	2.5<d≤3	3≤d≤40	°C	J
54510	EN 10025-2	S355JR+N ⁽¹⁾ low Si Fe510DTCL	355	345	510-680	470-630	13	14	15	16	20	+20	27 ⁽⁴⁾

Explanationsq

- 1) Grades with N code can be normalized and/or hot formed by customers.
- 2) Tensile tests are applied to "Transversal" test samples.
- 3) Impact tests are not carried out if nominal thickness is lesser than 6 mm.
- 4) Impact tests are carried out if it is customer's request in order.

LOW ALLOYED GENERAL STRUCTURAL AND TUBE STEELS SUITABLE FOR NORMALISING

Standard: EN 10025 Part 2-2004

Chemical Composition (%)

Colakoglu Quality ID	Standard	Quality		C	Mn	Si	P	S	Cu	Ti	N ppm	Nb	Ceq
				max.	max.	max.	max.	max.	max.	max.	max.	max.	max.
51520	EN 10025-2	S355JR+N (Fe520DTCL)	Std.	0.24	1.60	0.55	0.035	0.01	0.55	0.01-0.03	120	0.005-0.03	0.45
51530	EN 10025-2	S355JR+N (Fe510DTCL1)	Std.	0.19-0.22	1.30-1.60	0.18-0.25	0.02	0.003	0.55	0.01-0.03	120	0.02-0.035	0.45

Explanations

- 1) Mechanical test is not applied.

**UNALLOYED STRUCTURAL STEELS SUITABLE FOR HOT FORMING (SRM PIPE PRODUCTION)
COLD ROLLING, NORMALIZING AND GALVANIZING**

Standard: EN 10025-Part2-2004

Chemical Composition (%)

Çolakoglu Quality ID	Standard	Quality	C (max.)		Mn	P	S	Cu	Al ⁽¹⁾		N ⁽¹⁾		Ce ⁽²⁾	
			d≤16	16<d≤40					min.	max.	min.	max.	min.	max.
41235	EN 10025-2	S235JR+N-low S1	Std.	0.17	1.4	0.035	0.035	0.55	—	—	0.012	0.35	—	—
42235	EN 10025-2	S235JR+N	Std.	0.17	1.4	0.025	0.025	0.55	0.020	—	—	0.35	—	—
41275	EN 10025-2	S275JR+N-low S1	Std.	0.21	1.5	0.035	0.035	0.55	—	—	0.012	0.40	—	—
42275	EN 10025-2	S275J2+N-low S1	Std.	0.18	1.5	0.025	0.025	0.55	—	—	0.012	0.40	—	—

Explanations

- 1) The maximum value for nitrogen does not apply if the chemical composition shows a minimum aluminium content of 0.020 %.
- 2) Ce_{eq} is calculated by %CE (I_W) = C+Mn/6+ (Cr+Mo+V)/5+(Ni+Cr)/15 formula.

Mechanical Properties

Çolakoglu Quality ID	Standard	Quality	Re		Rm ⁽²⁾ N/mm ²	A(%) min.		Impact (long.) ⁽³⁾ KJc						
			min.	d : thickness, mm		A ₈₀	A ₅	Temp.						
								°C	min.					
41235	EN 10025-2	S235JR+N-low S1	≤16	16<d≤40	<3	3≤d<40	1.5<d≤2	2.5<d≤3	3≤d≤40	J	—	—	—	—
42235	EN 10025-2	S235JR+N	235	225	360-510	360-510	16	17	18	19	24	+20	27 ⁽⁴⁾	—
41275	EN 10025-2	S275JR+N-low S1	275	265	430-580	410-560	14	15	16	17	21	+20	27 ⁽⁴⁾	—
42275	EN 10025-2	S275J2+N-low S1	275	265	430-580	410-560	14	15	16	17	21	+20	27	—

Explanations

- 1) Grades with Nt code can be normalized and/or hot formed by customers.
- 2) Tensile tests are applied to "Transveisal" test samples.
- 3) Impact tests are not carried out if nominal thickness is lesser than 6 mm.
- 4) Impact tests are carried out if it is customer's request in order.

UNALLOYED STRAP STEELS FOR COLD ROLLING AND GALVANIZING

Standard: EN 10025-Part 2-2004

		Chemical Composition (%)										
Colakoglu Quality ID	Standard	Quality	C (max.)	Mn	Si	P	S	Cu	Al ⁽¹⁾	N ⁽¹⁾	Ceq ⁽²⁾	
51238	EN 10025-2	S235JR Strap Steel	d≤16	16<d≤40	max.	max.	max.	max.	max.	max.	max.	
			0.17	0.17	1.4	—	0.035	0.035	0.55	—	0.012	0.35
54238	EN 10025-2	S235JR Strap Steel with low Si	Sgd.	0.21	1.5	—	0.035	0.035	0.55	—	0.012	0.35

Explanations

- 1) The maximum value for nitrogen does not apply if the chemical composition shows a minimum aluminium content of 0.020%.
- 2) Ceq is calculated by %CE (IIW) = C+Mn/6+(C+Mo+V)/5+(Ni+Cr)/15 formula.

		Mechanical Properties												
Colakoglu Quality ID	Standard	Quality	Re		Rm ⁽¹⁾		A ₈₀		A ₅		Impact (long.) ⁽²⁾			
			N/mm ²		N/mm ²		A ₈₀		A ₅		KJc			
			min.	min.	d : thickness, mm		d : thickness, mm		Temp.		min.			
			d : thickness, mm	d : thickness, mm	d : thickness, mm		d : thickness, mm		°C		J			
51238	EN 10025-2	S235JR Strap Steel	≤16	235	<3	360-510	360-510	16	17	18	19	24	+20	27 ⁽³⁾
			16<d≤40	235	3≤d<40	360-510	360-510	16	17	18	19	24	+20	27 ⁽³⁾
54238	EN 10025-2	S235JR Strap Steel with low Si	235	225	360-510	360-510	16	17	18	19	24	+20	27 ⁽³⁾	

Explanations

- 1) Tensile tests are applied to "transversal" test samples.
- 2) Impact tests are not carried out if nominal thickness is lesser than 6 mm.
- 3) Impact tests are carried out if it is customer's request in order.

STRUCTURAL STEELS FOR SHIP BUILDING

Standard: **ABS-Part 2-2013**

Chemical Composition (%)

Colakoglu Quality ID	Standard	Quality		C	Si	Mn	P	S
			Std.	max.	max.	max.	max.	max.
57701	ABS-Part 2-2013	ABS Grade A	Std.	0.21	0.50	2.5XC	0.035	0.035
57702	ABS-Part 2-2013	ABS Grade B	Std.	0.21	0.35	0.60	0.035	0.035

Explanations

1) C+(Mn/6) value should be max. %0.40.

Mechanical Properties

Colakoglu Quality ID	Standard	Quality				Impact ⁽²⁾ (tran.)	
			Re(min.)	Rm ⁽¹⁾	A 5 (%)	Temp.	KVc (min.)
			N/mm ²		min.	°C	J
57701	ABS-Part 2-2013	ABS Grade A	235	400-520	22	20	-
57702	ABS-Part 2-2013	ABS Grade B	235	400-520	22	0	27

UNALLOYED GENERAL STRUCTURAL STEEL

Standard: **JIS G3101-2005**

Chemical Composition (%)

Colakoglu Quality ID	Standard	Quality		C	Mn	Si	P	S
			Std.	max.	max.		max.	max.
93400	JIS G 3101	SS400	Std.	-	-	-	0.050	0.050

Mechanical Properties

Colakoglu Quality ID	Standard	Quality	Re ⁽¹⁾		Rm ⁽¹⁾	A (%)			Bending
			N/mm ²		N/mm ²	(d=thickness)			(long.;180°)
			≤16	16<d≤40		d≤5	5<d≤16	16<d≤50	(d=thickness)
			min.	min.	min.	min.	min.	min.	mrB
93400	JIS G 3101	SS400	245	235	400-510	21	17	21	1.5d

Explanations

1) Tensile tests are applied to "Longitudinal" test samples.

CHROME ADDED GENERAL STRUCTURAL STEELS									
Standard: JIS G3101-2005									
Chemical Composition (%)									
Colakoglu Quality ID	Standard	Quality		C	Mn	Si	P	S	
			Std.	max.	max.		max.	max.	
93430	JIS G 3101	SS400-with Cr	Std.	-	-	-	0.050	0.050	

Mechanical Properties									
Colakoglu Quality ID	Standard	Quality	Re ⁽¹⁾		Rm ⁽¹⁾	A (%)			Bending
			N/mm ²		N/mm ²	(d=thickness)			(long.;180°)
			≤16	16<d≤40		d≤5	5<d≤16	16<d≤50	(d=thickness)
			min.	min.	min.	min.	min.	mrB	
93430	JIS G 3101	SS400-with Cr	245	235	400-510	21	17	21	1.5d

Explanations

1) Tensile tests are applied to "Longitudinal" test samples.

BORON ADDED GENERAL STRUCTURAL STEELS									
Standard: JIS G3101-2005									
Chemical Composition (%)									
Colakoglu Quality ID	Standard	Quality		C	Mn	Si	P	S	B
			Std.	max.	max.		max.	max.	ppm
93420	JIS G 3101	SS400-with B	Std.	-	-	-	0.050	0.050	20-50

Mechanical Properties									
Colakoglu Quality ID	Standard	Quality	Re ⁽¹⁾		Rm ⁽¹⁾	A (%)			Bending
			N/mm ²		N/mm ²	(d=thickness)			(long.;180°)
			≤16	16<d≤40		d≤5	5<d≤16	16<d≤50	(d=thickness)
			min.	min.	min.	min.	min.	mrB	
93420	JIS G 3101	SS400-with B	245	235	400-510	21	17	21	1.5d

Explanations

1) Tensile tests are applied to "Longitudinal" test samples.

HOT ROLLED LOW CARBON COMMERCIAL QUALITY STEELS SUITABLE FOR COLD FORMING

Standard: JIS G3131-2005

Chemical Composition (%)

Colakoglu Quality ID	Standard	Quality		C	Mn	Si	P	S
				max.	max.		max.	max.
93111	JIS G 3131	SPHC	Std.	0.15	0.60	-	0.050	0.050

Mechanical Properties

Colakoglu Quality ID	Std.	Quality	Rm ⁽¹⁾	A (%)						Bending
			N/mm ²	(d=thickness)						(long.;180°) (mrb)
				1.2≤d<1,6	1.6≤d<2.0	2.0≤d<2.5	2.5≤d<3.2	3.2≤d<4.0	4.0≤d	(d=thickness 3.2≤d)
				min.	min.	min.	min.	min.	min.	
93111	JIS G 3131	SPHC	270	27	29	29	29	31	31	0.5d

Explanations

1) Tensile tests are applied to "Longitudinal" test samples.

LOW CARBON STEELS WITH BORON SUITABLE FOR COLD FORMING

Standard: JIS G3131-2005

Chemical Composition (%)

Colakoglu Quality ID	Standard	Quality		C	Mn	Si	P	S	B
				max.	max.		max.	max.	ppm
93211	JIS G 3131	SPHC-with B	Std.	0.15	0.60	-	0.050	0.050	20-50

Mechanical Properties

Colakoglu Quality ID	Standard	Quality	Rm ⁽¹⁾	A (%)						Bending
			N/mm ²	(d=thickness)						(long.;180°) (mrb)
				1.2≤d<1,6	1.6≤d<2.0	2.0≤d<2.5	2.5≤d<3.2	3.2≤d<4.0	4.0≤d	(d=thickness 3.2≤d)
				min.	min.	min.	min.	min.	min.	
93211	JIS G 3131	SPHC-with B	270	27	29	29	29	31	31	0.5d

Explanations

1) Tensile tests are applied to "Longitudinal" test samples.

**HOT ROLLED LOW CARBON PIPE AND PROFILE STEELS SUITABLE
FOR COLD FORMING AND GALVANIZING**

Standard: JIS G3132-2005

Chemical Composition (%)

Colakoglu Quality ID	Standard	Quality		C	Mn	Si	P	S
				max.	max.	max.	max.	max.
93270	JIS G 3132	SPHT-1	Std.	0.10	0.50	0.040	0.040	0.040
93340	JIS G 3132	SPHT-2	Std.	0.18	0.60	0.35	0.040	0.040

Mechanical Properties

Colakoglu Quality ID	Standard	Quality	Rm ⁽¹⁾	A (%)				Bending	
			N/mm ²	(d=thickness)				(long.,180°) (mrb)	
				1.2≤d<1,6	1.6≤d<3.0	3.0≤d<6.0	6.0≤d≤13	(d=thickness 3.2≤d)	
				min.	min.	min.	min.	3.0≤d	3.0<d≤13
93270	JIS G 3132	SPHT-1	270	30	32	35	37	-	0.5d
93340	JIS G 3132	SPHT-2	340	25	27	30	32	1d	1.5d

Explanations

1) Tensile tests are applied to "Longitudinal" test samples.

ATMOSPHERE CORROSION RESISTANT STEELS

Standard: JIS G3125-2005

Chemical Composition (%)

Colakoglu Quality ID	Standard	Quality		C	Si	Mn ⁽¹⁾	P	S	Cu	Cr	Ni
				max.	max.	max.	max.	max.	max.	max.	max.
93125	JIS G3125	SPA - H	Std.	0.12	0.20 - 0.75	0.60	0.070-0.150	0.035	0.25 - 0.55	0.30 - 1.25	0.65

Explanations

1) Upper limit for Mn can be 1 % by agreement.

Mechanical Properties

Colakoglu Quality ID	Standard	Quality		Re	Rm ⁽¹⁾	A (%)		Bending		
			Sample Thickness	N/mm ²		A ₅₀	A ₂₀₀	(long.,180°) mrb		
				(d=thickness)		min.	min.	min.	min.	(d=thickness)
				d≤6	6<d≤16	355	490	22	15	0.5 d
93125	JIS G3125	SPA - H	6<d≤16	355	490	22	15			1.5 d

Explanations

1) Tensile tests are applied to "Longitudinal" test samples.

UNALLOYED GENERAL STRUCTURAL STEELS SUITABLE FOR GALVANIZING AND BENDING

Standard: AS NZS 1594-2002

Chemical Composition (%)

Colakoglu Quality ID	Standard	Quality		C	Mn	Si	P	S	Cr	Ni	Cu	Al	Ti	N ppm	Ceq
			Std.	max.	max.	max.	max.	max.	max.	max.	max.	max.	min.	max.	max.
94250	AS NZS 1594	HA250-low Si ¹⁾	Std.	0.20	1.20	0.35	0.040	0.030	0.25	0.25	0.25	0.10	0.040	120	0.39

Explanations

1) Nb+V = % 0.03 max.

Mechanical Properties

Colakoglu Quality ID	Standard	Quality	Re	Rm ¹⁾	A (%)						Bending ²⁾		
			N/mm ²		d≤3			3<d			(tran.;180°, d=thickness, mdb)		
			min.	min.	A ₅₀	A ₈₀	A ₂₀₀	A ₅₀	A ₈₀	A ₂₀₀	d≤3	3<d≤5	5<d
94250	AS NZS 1594	HA250-low Si	250	350	22	20	16	26	24	17	d	d	2d

Explanations

- 1) Tensile tests are applied to "Longitudinal" test samples.
- 2) Bending tests are applied to "Transverse" test samples.

UNALLOYED GENERAL STRUCTURAL STEELS SUITABLE FOR GALVANIZING AND BENDING

Standard: AS NZS 1594-2002

Chemical Composition (%)

Colakoglu Quality ID	Standard	Quality		C	Mn	Si	P	S	Cr	Ni	Cu	Al	Ti	N ppm	Ceq
			Std.	max.	max.	max.	max.	max.	max.	max.	max.	max.	min.	max.	max.
94350	AS NZS 1594	HA350-low Si ¹⁾	Std.	0.20	1.6	0.35	0.040	0.030	0.25	0.25	0.25	0.10	-	120	0.44

Explanations

1) For the quality HA350, V could be %0.10 max. or Nb+V+Ti could be %0.15 max.

Mechanical Properties

Colakoglu Quality ID	Standard	Quality	Re	Rm ¹⁾	A(%)						Bending ²⁾		
			N/mm ²		d≤3			3<d			(tran.;180°, d=thickness, mdb)		
			min.	min.	A ₅₀	A ₈₀	A ₂₀₀	A ₅₀	A ₈₀	A ₂₀₀	d≤3	3<d≤5	5<d
94350	AS NZS 1594	HA350-low Si	350	430	18	16	14	22	20	15	2d	2d	3d

Explanations

- 1) Tensile tests are applied to "Longitudinal" test samples.
- 2) Bending tests are applied to "Transverse" test samples.

UNALLOYED GENERAL STRUCTURAL STEELS

Standard: CSAG40

Chemical Composition (%)

Colakoglu Quality ID	Standard	Quality		C	Mn	Si	P	S	Cu	Al	N ppm
				max.			max.	max.		min.	max.
96350	CSAG40	350 WT	Std.	0.22	0.80-1.50	0.15-0.40	0.03	0.04	0.20-0.60	0.02	120
96450	CSAG40	44W/50W	Std.	0.22	0.50-1.50	0.40	0.040	0.050	-	-	-

Explanations

1) Nb + V = % 0.15 max.

Mechanical Properties

Colakoglu Quality ID	Standard	Quality	Re	Rm		A (%)		Impact (long.)	
			N/mm ²			A ₅₀	A ₂₀₀	Temp.	KVc (min)
			min.	min.	max.	min.	min.	°C	J
96350	CSAG40	350 WT	350	450	650	22	19	-20	27
96450	CSAG40	44W/50W	345	450	655	22	19	-	-

HIGH STRENGTH AND MICROALLOYED STEELS SUITABLE FOR COLD FORMING AND BENDING

Standard: SAE J2340-1999-10

Chemical Composition (%)

Colakoglu Quality ID	Standard	Quality		C	P	S	Cr	Ni	Cu	Mo	V	Ti	Nb
				max.	max.	max.	max.	max.	max.	max.	min.	max.	min.
38340	SAE J2340	340XF	Std.	0.13	0.060	0.015	0.150	0.200	0.200	0.060	0.005	0.005	0.005
38420	SAE J2340	420XF	Std.	0.13	0.060	0.015	0.150	0.200	0.200	0.060	0.005	0.005	0.005

Mechanical Properties

Colakoglu Quality ID	Standard	Quality	Re	Rm	A (%)
			N/mm ²		A ₅₀
			min.	min.	
38340	SAE J2340	340XF	340-440	410	25
38420	SAE J2340	420XF	420-520	490	22

Explanations

1) Tensile tests are applied to "Longitudinal" test samples.

HOT ROLLED CARBON STEELS											
Std. : SAE J403-2001											
Chemical Composition (%)											
Colakoglu Quality ID	Standard	Quality		C	Mn	P	S	Cu	Ni	Cr	Mo
				max.	max.	max.	max.	max.	max.	max.	max.
91006	SAE J 403	SAE 1006	Std.	0.08	0.25-0.40	0.030	0.050	0.20	0.25	0.20	0.06
91008	SAE J 403	SAE 1008	Std.	0.10	0.30-0.50	0.030	0.050	0.20	0.25	0.20	0.06
91108	SAE J 403	SAE 1008-Modified	Std.	0.10	0.30-0.50	0.030	0.050	0.20	0.25	0.20	0.06
91010	SAE J 403	SAE 1010	Std.	0.08 - 0.13	0.30 - 0.60	0.030	0.050	0.20	0.25	0.20	0.06
91110	SAE J 403	SAE 1010-Modified	Std.	0.08 - 0.13	0.30 - 0.60	0.030	0.050	0.20	0.25	0.20	0.06
91210	SAE J 403	SAE 1010 with Ca	Std.	0.08 - 0.13	0.30 - 0.60	0.030	0.035	0.20	0.25	0.20	0.06
91012	SAE J 403	SAE 1012	Std.	0.10-0.15	0.30-0.60	0.030	0.050	0.20	0.25	0.20	0.06
91112	SAE J 403	SAE 1012-High Mn	Std.	0.10-0.15	0.30-0.60	0.030	0.050	0.20	0.25	0.20	0.06
91015	SAE J 403	SAE 1015	Std.	0.13 - 0.18	0.30 - 0.60	0.030	0.050	0.20	0.25	0.20	0.06
91017	SAE J 403	SAE 1017	Std.	0.15-0.20	0.30 - 0.60	0.030	0.050	0.20	0.25	0.20	0.06
91018	SAE J 403	SAE 1018	Std.	0.15 - 0.20	0.60 - 0.90	0.030	0.050	0.20	0.25	0.20	0.06
91118	SAE J 403	SAE 1018-Modified	Std.	0.15 - 0.20	0.60 - 0.90	0.030	0.050	0.20	0.25	0.20	0.06
91020	SAE J 403	SAE 1020	Std.	0.18 - 0.23	0.30 - 0.60	0.030	0.050	0.20	0.25	0.20	0.06
91121	SAE J 403	SAE 1020-low Si	Std.	0.18 - 0.23	0.60 - 0.90	0.030	0.050	0.20	0.25	0.20	0.06
91022	SAE J 403	SAE 1022-Modified	Std.	0.18 - 0.23	0.70 - 1.00	0.030	0.050	0.20	0.25	0.20	0.06
91222	SAE J 403	SAE 1022-high Mn	Std.	0.17-0.22	0.70 - 1.60	0.030	0.050	0.20	0.25	0.20	0.06
91122	SAE J 403	SAE 1022-low Si	Std.	0.18 - 0.23	0.70 - 1.00	0.030	0.050	0.20	0.25	0.20	0.06
91025	SAE J 403	SAE 1025	Std.	0.22 - 0.28	0.30 - 0.60	0.030	0.050	0.20	0.25	0.20	0.06
91026	SAE J 403	SAE 1026	Std.	0.22 - 0.28	0.60 - 0.90	0.030	0.050	0.20	0.25	0.20	0.06
91030	SAE J 403	SAE 1030	Std.	0.28 - 0.34	0.60 - 0.90	0.030	0.050	0.20	0.25	0.20	0.06

HOT ROLLED MEDIUM AND HIGH CARBON STEELS											
Standard: SAE J403-2001											
Chemical Composition (%)											
Colakoglu Quality ID	Standard	Quality		C	Mn	P	S	Cu	Ni	Cr	Mo
				max.	max.	max.	max.	max.	max.	max.	max.
91040	SAE J 403	SAE 1040	Std.	0.37-0.44	0.60 - 0.90	0.030	0.050	0.20	0.25	0.20	0.06
91045	SAE J 403	SAE 1045	Std.	0.43 - 0.50	0.60 - 0.90	0.030	0.050	0.20	0.25	0.20	0.06
91145	SAE J 403	SAE 1045-Special	Std.	0.42 - 0.48	0.50 - 0.80	0.030	0.050	0.20	0.25	0.20	0.06
91050	SAE J 403	SAE 1050	Std.	0.48 - 0.55	0.60 - 0.90	0.030	0.050	0.20	0.25	0.20	0.06
91055	SAE J 403	SAE 1055	Std.	0.5 - 0.6	0.6 - 0.9	0.030	0.050	0.20	0.25	0.20	0.06
91060	SAE J 403	SAE 1060	Std.	0.55 - 0.65	0.60 - 0.90	0.030	0.050	0.20	0.25	0.20	0.06

HOT ROLLED MEDIUM AND HIGH CARBON STEELS										
Std. :SAE J 404-2000										
Chemical Composition (%)										
Colakoglu Quality ID	Standard	Quality	C	Mn	P	S	Si	Ni	Cr	Mo
			max.	max.	max.	max.	max.	max.	max.	max.
92130	SAE J 404-2000	SAE 4130	0.28-0.33	0.40-0.60	0.030	0.040	0.15-0.35	-	0.80-1.10	0.15-0.25

STEELS FOR PIPE LINES												
Standard: API 5L 45th Edition-2012/ISO 3183-2012												
Chemical Composition (%)												
Colakoglu Quality ID	Standard	Quality		C ⁽³⁾	Mn ⁽³⁾	P	S	Cr	Ni	Cu	Mo	B
				max.	max.	max.	max.	max.	max.	max.	max.	max.
95130 ⁽²⁾	API 5L / ISO 3183	A / L210 / PSL1	Std.	0.22	0.90	0.030	0.030	0.50	0.50	0.50	0.15	10
95135 ^(1,2,5)	API 5L / ISO 3183	B / L245 / PSL1	Std.	0.26	1.20	0.030	0.030	0.50	0.50	0.50	0.15	10
95142 ^(1,5)	API 5L / ISO 3183	X42 / L290 / PSL1	Std.	0.26	1.30	0.030	0.030	0.50	0.50	0.50	0.15	10
95146 ^(1,5)	API 5L / ISO 3183	X46 / L320 / PSL1	Std.	0.26	1.40	0.030	0.030	0.50	0.50	0.50	0.15	10
95152 ^(1,5)	API 5L / ISO 3183	X52 / L360 / PSL1	Std.	0.26	1.40	0.030	0.030	0.50	0.50	0.50	0.15	10
95156 ^(1,5)	API 5L / ISO 3183	X56 / L390 / PSL1	Std.	0.26	1.40	0.030	0.030	0.50	0.50	0.50	0.15	10
95652 ^(1,6)	API 5L / ISO 3183	X52 / L360 / PSL1	Std.	0.26	1.40	0.030	0.030	0.50	0.50	0.50	0.15	10
95160 ^(1,6)	API 5L / ISO 3183	X60 / L415 / PSL1	Std.	0.26	1.40	0.030	0.030	0.50	0.50	0.50	0.15	10
95165 ^(1,6)	API 5L / ISO 3183	X65 / L450 / PSL1	Std.	0.26	1.45	0.030	0.030	0.50	0.50	0.50	0.15	10
95170 ^(1,6)	API 5L / ISO 3183	X70 / L485 / PSL1	Std.	0.26	1.65	0.030	0.030	0.50	0.50	0.50	0.15	10

Explanations

- 1) Nb+V+Ti≤0.15
- 2) Nb+V≤0.06
- 3) For each reduction of 0.01 % for carbon, an increase of 0.05 % for manganese is permitted, up to a maximum of 1.65 % for L245, L290, L320 and L360 grades, 1.75 % for X56, X60 and X65 grades, 2.00% for X70 grade.
- 4) For L360/X52 and lower grades, 0.5 %, Cr : % 0.5, Ni : % 0.5 and Mo : % 0.15 is permitted.
- 5) Suitable for ERW Pipe Manufacturing
- 6) Suitable for Spiral Welded Pipe Manufacturing

Mechanical Properties					
Colakoglu Quality ID	Standard	Quality	Re	Rm ⁽¹⁾	Af(%)
			N/mm ²		
			min.	min.	min.
95130	API 5L / ISO 3183	A / L210 / PSL1	210	335	"2"
95135	API 5L / ISO 3183	B / L245 / PSL1	245	415	"2"
95142	API 5L / ISO 3183	X42 / L290 / PSL1	290	415	"2"
95146	API 5L / ISO 3183	X46 / L320 / PSL1	320	435	"2"
95152	API 5L / ISO 3183	X52 / L360 / PSL1	360	460	"2"
95156	API 5L / ISO 3183	X56 / L390 / PSL1	390	490	"2"
95652	API 5L / ISO 3183	X52 / L360 / PSL1	360	460	"2"
95160	API 5L / ISO 3183	X60 / L415 / PSL1	415	520	"2"
95165	API 5L / ISO 3183	X65 / L450 / PSL1	450	535	"2"
95170	API 5L / ISO 3183	X70 / L485 / PSL1	485	570	"2"

Explanations

- 1) Tensile tests are applied to "Transversal" test samples.
- 2) Af % = 1940 Axc0.2 / U0.9 (Axc : Cross sectional area,mm² ; U : Minimum tensile strength, N / mm²).

STEELS FOR PIPE LINES WITH STANDARD YIELD STRENGTH/TENSILE STRENGTH RATIO

Standard: API 5L 45th Edition-2012/ISO 3183-2012

Çolakoğlu Quality ID	Standard	Quality	Chemical Composition (%)														C equivalence	
			C ⁽⁵⁾ max.	Mn ⁽⁵⁾ max.	Si max.	P max.	S max.	Cr max.	Ni max.	Cu max.	Mo max.	Ti max.	V max.	Nb max.	B ppm, max.	CE _{FW}	CE _{Feu}	
95035 ^(2,4)	API 5L/ISO 3183	BW / L245M / PSL2	Std.	0.22	1.20	0.45	0.025	0.015	0.30	0.30	0.50	0.15	0.04	0.05	0.05	10	0.43	0.25
95735 ^(2,7)	API 5L/ISO 3183	BW / L245M / PSL2	Std.	0.22	1.20	0.45	0.025	0.015	0.30	0.30	0.50	0.15	0.04	0.05	0.05	10	0.43	0.25
95036 ^(3,4)	API 5L/ISO 3183	BW / L245M / PSL2	Std.	0.22	1.30	0.45	0.025	0.015	0.30	0.30	0.50	0.15	0.04	0.05	0.05	10	0.43	0.25
95042 ⁽⁴⁾	API 5L/ISO 3183	X42M / L290M / PSL2	Std.	0.22	1.30	0.45	0.025	0.015	0.30	0.30	0.50	0.15	0.04	0.05	0.05	10	0.43	0.25
95046 ^(3,4)	API 5L/ISO 3183	X46M / L320M / PSL2	Std.	0.22	1.40	0.45	0.025	0.015	0.30	0.30	0.50	0.15	"3"	"3"	"3"	10	0.43	0.25
95752 ^(3,4)	API 5L/ISO 3183	X52M / L360M / PSL2	Std.	0.22	1.40	0.45	0.025	0.015	0.30	0.30	0.50	0.15	"3"	"3"	"3"	10	0.43	0.25
95052 ^(2,3,7)	API 5L/ISO 3183	X52M / L360M / PSL2	Std.	0.12	1.60	0.45	0.025	0.015	0.50	0.50	0.50	0.50	"3"	"3"	"3"	10	0.43	0.25
95056 ^(3,7)	API 5L/ISO 3183	X56M / L390M / PSL2	Std.	0.12	1.60	0.45	0.025	0.015	0.50	0.50	0.50	0.50	"3"	"3"	"3"	10	0.43	0.25
95060 ^(4,7)	API 5L/ISO 3183	X60M / L415M / PSL2	Std.	0.12	1.70	0.45	0.025	0.015	0.50	0.50	0.50	0.50	"3"	"3"	"3"	10	0.43	0.25
95065 ^(4,7)	API 5L/ISO 3183	X65M / L450M / PSL2	Std.	0.22	1.40	0.45	0.025	0.015	0.30	0.30	0.50	0.15	"3"	"3"	"3"	10	0.43	0.25
95070 ^(4,7)	API 5L/ISO 3183	X70M / L485M / PSL2	Std.	0.12	1.60	0.45	0.025	0.015	0.50	0.50	0.50	0.50	"3"	"3"	"3"	10	0.43	0.25

Explanations

- 1) Nb+V≤0.06
- 2) Cu 0.5 % , Cr 0.3 % , Ni 0.3 % and Mo 0.15%
- 3) Nb+V+Ti≤0.15
- 4) Cu 0.5 % , Cr 0.5 % , Ni 0.5 % and Mo 0.5%
- 5) For each reduction of 0.01 % for carbon, an increase of 0.05 % for manganese is permitted, up to a maximum of 1.50 for X42PSL2, X46PSL2 and X52PSL2
- 6) 1.65 % for X56PSL2, X60PSL2 and X65PSL2 grades and up to a maximum 2.00 % for X70PSL2 grade.
- 7) Suitable for ERW Pipe Manufacturing
- 7) Suitable for Spiral Welded Pipe Manufacturing

STEELS FOR PIPE LINES WITH STANDARD YIELD STRENGTH/TENSILE STRENGTH RATIO

Standard: API 5L 45th Edition-2012/ISO 3183-2012

Cologlu Quality ID	Standard	Quality	Mechanical Properties						Impact ²⁾⁽³⁾ (tran.)			DWTT (tran.)	
			Rt _{0.5}		Rm ⁽¹⁾		Rt _{0.5} /Rm	A ₅₀ (%)	Temp. °C	KJc	J	% Shear Area	min.
			min.	max.	min.	max.							
95035	API 5L/ISO 3183	BM / L245M / PSL2	245	450	415	760	0.93	"2"	0	40	85	85	
95735	API 5L/ISO 3183	BM / L245M / PSL2	245	450	415	760	0.93	"2"	0	40	85	85	
95036	API 5L/ISO 3183	BM / L245M / PSL2	245	450	415	760	0.93	"2"	0	40	85	85	
95042	API 5L/ISO 3183	X42M / L290M / PSL2	290	495	415	760	0.93	"2"	0	40	85	85	
95046	API 5L/ISO 3183	X46M / L320M / PSL2	320	525	435	760	0.93	"2"	0	40	85	85	
95752	API 5L/ISO 3183	X52M / L360M / PSL2	360	530	460	760	0.93	"2"	0	40	85	85	
95052	API 5L/ISO 3183	X52M / L360M / PSL2	360	530	460	760	0.93	"2"	0	40	85	85	
95056	API 5L/ISO 3183	X56M / L390M / PSL2	390	545	490	760	0.93	"2"	0	40	85	85	
95060	API 5L/ISO 3183	X60M / L415M / PSL2	415	565	520	760	0.93	"2"	0	40	85	85	
95065	API 5L/ISO 3183	X65M / L450M / PSL2	450	600	535	760	0.93	"2"	0	54	85	85	
95070	API 5L/ISO 3183	X70M / L485M / PSL2	485	635	570	760	0.93	"2"	0	68	85	85	

Explanations

- 1) Tensile tests are applied to "Transversal" test samples.
- 2) A₅₀ % = 1944.500,2 / U0,9 (50 : Cross sectional area, mm² ; U : tensile strength N / mm²)
- 3) Impact tests are not carried out if nominal thickness is lesser than 6 mm.
- 4) Impact tests are carried out if it is customer's request in order.
- 5) DWTT tests are applied to "Transverse" test samples.

STEELS FOR PIPE LINES WITH LOW YIELD STRENGTH/TENSILE STRENGTH RATIO

Standard: API 5L 45th Edition-2012/ISO 3183-2012

Çolakoglu Quality ID	Standard	Quality	Chemical Composition (%)											C equivalence			
			C ⁽⁴⁾ max.	Mn ⁽⁴⁾ max.	Si max.	P max.	S max.	Cr max.	Ni max.	Cu max.	Mo max.	Ti max.	V max.	Nb max.	B ppm, max.	C _{Feu}	C _{Feu}
95835 ^{2,5)}	API 5L/ISO 3183	BM / L245M / PSL2	Std.	1.20	0.45	0.025	0.015	0.30	0.30	0.50	0.15	0.04	0.05	0.05	10	0.43	0.25
95842 ^{4,5)}	API 5L/ISO 3183	X42M / L290M / PSL2	Std.	1.30	0.45	0.025	0.015	0.30	0.30	0.50	0.15	0.04	0.05	0.05	10	0.43	0.25
95846 ^{4,5)}	API 5L/ISO 3183	X46M / L320M / PSL2	Std.	1.30	0.45	0.025	0.015	0.30	0.30	0.50	0.15	0.04	0.05	0.05	10	0.43	0.25
95852 ^{2,5)}	API 5L/ISO 3183	X52M / L360M / PSL2	Std.	1.40	0.45	0.025	0.015	0.30	0.30	0.50	0.15	"3"	"3"	"3"	10	0.43	0.25
95952 ^{2,3,6)}	API 5L/ISO 3183	X52M / L360M / PSL2	Std.	1.40	0.45	0.025	0.015	0.30	0.30	0.50	0.15	"3"	"3"	"3"	10	0.43	0.25

Explanations

- 1) Nb+V≤0.06
- 2) Cu 0.5 % , Cr 0.3 % , Ni 0.3 % and Mo 0.15%
- 3) Nb+V+Ti≤0.15
- 4) For each reduction of 0.01 % for carbon, an increase of 0.05 % for manganese is permitted, up to a maximum of 1.50 for X42PSL2, X46PSL2 and X52PSL2 .
- 5) Suitable for ERW Pipe Manufacturing
- 6) Suitable for Spiral Welded Pipe Manufacturing

Çolakoglu Quality ID	Standard	Quality	Mechanical Properties										
			Rt _{0.2} ⁽⁵⁾		Rm ⁽¹⁾		A ₅₀ (%)		Darbe ⁽⁶⁾ (tran.)		DWTT (tran.)		
			min.	max.	min.	max.	min.	max.	S _{0.2}	J	%Shear Area	min.	
95835	API 5L/ISO 3183	BM / L245M / PSL2	245	450	415	760	0.93	0.93	"2"	0	40	85	85
95842	API 5L/ISO 3183	X42M / L290M / PSL2	290	495	415	760	0.93	0.93	"2"	0	40	85	85
95846	API 5L/ISO 3183	X46M / L320M / PSL2	320	525	435	760	0.93	0.93	"2"	0	40	85	85
95852	API 5L/ISO 3183	X52M / L360M / PSL2	360	530	460	760	0.93	0.93	"2"	0	40	85	85
95952	API 5L/ISO 3183	X52M / L360M / PSL2	360	530	460	760	0.93	0.93	"2"	0	40	85	85

Explanations

- 1) Tensile tests are applied to "Transversal" test samples.
- 2) A₅₀ % = 1944 S_{0.2}² / U² (S_{0.2} : Cross sectional area, mm² ; U : tensile strength N / mm²)
- 3) Impact tests are not carried out if nominal thickness is lesser than 6 mm.
- 4) Impact tests are carried out if it is customer's request in order.
- 5) DWTT tests are applied to "Transverse" test samples.

STEELS FOR PIPE LINES

Standard: EN ISO3183-2012 Annex M

Chemical Composition (%)

Çolakoğlu Quality ID	Standard	Quality	C	Mn	Si	P	S	Cr	Ni	Cu	Al	Mo	Ti	V	Nb	N	B
95560	EN ISO3183-2012 Annex M	L415NE PSL2 (API 5L X60N)	max. 0.23	max. 1.40	max. 0.45	max. 0.025	max. 0.015	max. 0.30	max. 0.30	max. 0.25	min. 0.015-0.060	min. 0.10	max. 0.04	max. 0.10	max. 0.05	ppm max. 120	ppm max. 10
95552	EN ISO3183-2012 Annex M	L360N PSL2 (API 5L X52N)	Std. 0.24	1.40	0.45	0.025	0.015	0.30	0.30	0.50	0.015-0.060	0.15	0.04	0.10	0.05	120	10

Explanations

1) Nb+V+Ti ≤ 0.15

Mechanical Properties

Çolakoğlu Quality ID	Standard	Quality	Rt _{0.05}		Rm		Impact (tran.) Temp. °C	A ₅ (%) min.	Impact KV ₂ (min) J	Bending mdb
			N/mm ²		N/mm ²					
			min.	max.	min.	max.				
95560	EN ISO3183-2012 Annex M	L415NE PSL2 (API 5L X60N)	415	565	520	760	0.85	18	0	5d
95552	EN ISO3183-2012 Annex M	L360N PSL2 (API 5L X52N)	360	530	460	760	0.93	A ₅ (%): 27	0	40

STEELS FOR CASING AND / OR TUBING

Standard: API 5CT-2011

Chemical Composition (%)

Colokoglu Quality ID	Standard	Quality	C	Mn	Si	P	S	Cr	Ni	Sn	Cu	Al	Mo	V	Ti	N	B	Ca	Nb	
																				max.
95254	API 5CT	J55 Upgradeable (Tubing)	Std.	0.25-0.30	1.20-1.40	0.15-0.25	0.015	0.005	0.10	0.07	0.012	0.15	0.015-0.050	0.030	0.008	0.010	90	5	15-50	-
95255	API 5CT	J55 Upgradeable (Casing)	Std.	0.23-0.27	1.20-1.40	0.15-0.30	0.020	0.005	0.15-0.35	0.07	0.012	0.15	0.045max.	0.030	0.008	0.010	100	5	15-50	-
95256	API 5CT	J55 Upgradeable	Std.	0.23-0.27	1.20-1.40	-	0.020	0.010	-	-	-	-	-	0.010	-	-	-	-	-	-
95257	API 5CT	J55 Upgradeable	Std.	0.24-0.27	1.25-1.35	0.15-0.25	0.020	0.005	0.20-0.30	-	-	-	-	.08-12	.010	-	-	5	15-50	-
95355	API 5CT	J55 regular	Std.	0.17-0.23	0.90-1.45	0.30	0.020	0.015	0.10	0.10	0.015	0.15	0.015-0.050	0.080	0.006	0.020	100	5	15-50	0.05
95356	API 5CT	J55 regular	Std.	0.22-0.26	1.10-1.30	0.15-0.30	0.020	0.008	0.10	0.07	0.012	0.15	0.015-0.050	0.040	0.008	0.010	90	5	15-50	-
95455	API 5CT	5CT J55 Upgradeable	Std.	0.025-0.029	1.25-1.40	0.20-0.25	0.015	0.005	-	0.07	0.012	0.15	0.045max.	0.030	0.008	0.018-0.035	100	10-25	15-50	-

Mechanical Properties

Colokoglu Quality ID	Standard	Quality	Re	Rm ¹⁾		A _{5g} (%)		Impact (long.) ²⁾	
				N/mm ²		KJc (min.)		Temp. °C	J
				min.	max.	min.	max.		
95254	API 5CT	J55 Upgradeable (Tubing)	379	552	517	—	(3)	-20	27
95255	API 5CT	J55 Upgradeable (Casing)	379	552	517	—	(3)	-20	27
95256	API 5CT	J55 Upgradeable	379	552	517	—	(3)	-20	27
95257	API 5CT	J55 Upgradeable	379	552	517	—	(3)	-20	27
95355	API 5CT	J55 regular	379	552	517	—	(3)	-20	27
95356	API 5CT	J55 regular	379	552	517	—	(3)	-20	27
95455	API 5CT	5CT J55 Upgradeable	379	552	517	—	(3)	-20	27

Explanations

- 1) Tensile and impact tests are applied to "longitudinal" test samples.
- 2) Impact tests are not carried out if nominal thickness is lesser than 6 mm.
- 3) A_{5g} (%) = 1944 S_{0.4}² / U^{0.5}; S_{0.4}: sectional area, mm²; U: tensile strength, N/mm²

UNALLOYED GENERAL STRUCTURAL STEELS (FLOOR PLATE)

Standard: ASTM A 36-2005 Floor Plate Standard: ASTM A786

Chemical Composition (%)

Çolakoglu Quality ID	Standard	Quality		C ⁽²⁾	Mn ^(1,2)	Si	P	S
				max.		max.	max.	max.
56435 ⁽³⁾	ASTM A 36: 2005	ASTM A 36 ASTM A786	Std.	0.26	0.80-1.20	0.40	0.040	0.050

Explanations

- 1) Upper limit for Mn does not apply if the thickness of strips are 20 mm and thinner.
- 2) For each reduction of 0.01 % for carbon, an increase of 0.06 % for manganese is permitted, up to a maximum of 1.35
- 3) Optionally, Cu 0.20 % is permitted.

Mechanical Properties

Çolakoglu Quality ID	Standard	Quality	Re	Rm ⁽¹⁾	A (%)		Impact ⁽²⁾⁽³⁾	
			N/mm ²		A 50	A 200	Temp.	KVc (min)
			min.	min.	min.	min.	°C	J
56435	ASTM A 36: 2005	ASTM A 36 ASTM A786	250	400 - 550	23	20	-20	40

Explanations

- 1) Tensile tests are applied to "Transversal" test samples.
- 2) Impact tests are not carried out if nominal thickness is lesser than 6 mm.
- 3) Impact tests are carried out if it is customer's request in order.

**UNALLOYED GENERAL STRUCTURAL STEELS SUITABLE
FOR GALVANIZING (FLOOR PLATE)**

Standard: ASTM A 36-2005 Floor Plate Standard: ASTM A786

Chemical Composition (%)

Colakoglu Quality ID	Standard	Quality	Std.	C ⁽²⁾	Mn ^(1,2)	Si	P	S
				max.		max.	max.	max.
56437 ⁽³⁾	ASTM A 36: 2005	ASTM A 36 ASTM A786		0.26	0.80-1.20	0.40	0.040	0.050

Explanations

- 1) Upper limit for Mn. does not apply if the thickness of strips are 20 mm and thinner.
- 2) For each reduction of 0.01 % for carbon, an increase of 0.06 % for manganese is permitted, up to a maximum of 1.35.
- 3) Optionally, Cu 0.20 % is permitted.

Mechanical Properties

Colakoglu Quality ID	Standard	Quality	Re	Rm ⁽¹⁾	A (%)		Impact ⁽²⁾⁽³⁾	
			N/mm ²		A 50	A 200	Temp.	KVc (min)
			min.	min.	min.	min.	°C	J
56437	ASTM A 36: 2005	ASTM A 36 ASTM A786	250	400 - 550	23	20	-20	40

Explanations

- 1) Tensile tests are applied to "Transversal" test samples.
- 2) Impact tests are not carried out if nominal thickness is lesser than 6 mm.
- 3) Impact tests are carried out if it is customer's request in order.





HOT ROLLED FLAT STEEL PRODUCTS

PRODUCTION LIMITS
& TOLERANCES

Group No.	STEEL GRADES
4	<p>AS NZS 1594-2002 (HA350-low Si) ASTM A 1011/A 1011M-2007 (S5 Grade 50-low Si, S5 Grade 50, S5 Grade 55-low Si, S5 Grade 55, HSLAS Grade 50 Class 1-low Si, HSLAS Grade 50 Class 1, HSLAS Grade 55 Class 1 -low Si, HSLAS Grade 55 Class 1, HSLAS Grade 55 Class 2, HSLAS Grade 50 Class 1-with Cu) ASTM A 1018/A 1018M-07 (HSLAS Grade 50 Class 1, HSLAS Grade 50 Class 1-with Cu, HSLAS Grade 50 Class 1-with Si, HSLAS Grade 50 Class 1-with Cu+Si, HSLAS Grade 55 Class 1, HSLAS Grade 55 Class 1-with Si, HSLAS Grade 50 Class 2, HSLAS Grade 55 Class 2) ASTM A 500-2007 (Grade C) ASTM A 606 (Type 2) ASTM A572-2007 (Grade 50 Type 1, Grade 50 Type 2, Grade 55 Type 1, Grade 55 Type 2) CSAG40 (350 WT, 44W/50W) EN 10025-Part 2-2004 (E335, S355J0, S355JR, S355J2, S355J2+N, S355J2+N+Cu, S355JR+N-low Si, S355JR-low Si, S355J0-low Si, S355J2+N-low Si, S355J2-low Si, S355JRC-low Si, S355J0C-low Si, S355J2C-low Si, S355J2C+N, S355JRC, S355J2C+N-Special, S355JR-Special, S355JRC Special (S355J2C+N), S355J2C+N Special, S355JRC Special, S355J0-Special, S355JR+N-low Si (Fe510DTCL), S355JR+N (Fe520DTCL), S355JR+N (Fe510DTCL1)) EN 10025 Part 5-2004 (S355J0W, S355J2W, S355J0WP, S355J2WP) EN 10028-Part 2-2008 (P355GH) EN 10028-Part 3-2008 (P355NL1) EN 10083- Part 2 -2006 (28Mn6) EN 10083- Part 3 -2006 (30MnB5, 34MnB5, 27MnCrB5-2, 26MnB5, 22MnB5) EN 10120-2008 (P355NB) EN 10338-2009 (HCT500X (DP 500)) EN 10338-2010 (HDT580X (DP 600), HCT600X (DP 600)) SAE J403-2009 (SAE 1025, SAE 1026, SAE 1030) SAE J404-2000 (SAE 4130)</p>
5	<p>API 5CT-2011 (J55 Upgradeable (Tubing), J55 Upgradeable (Casing), J55 Upgradeable, J55 regular, 5CT J55 Upgradeable) EN 10025 Part 3 -2004 (S355N) EN 10083- Part 2 -2006 (C35E, C35E-Cr, C45E-Special) SAE J403-2009 (SAE 1040, SAE 1045, SAE 1045-Special)</p>
6	<p>EN 10083- Part 2 -2006 (C60E, C60E-Special, C60E-1-Cr) SAE J403-2009 (SAE 1050, SAE 1055, SAE 1060)</p>
7	<p>API 5L 45th Edition-2012/ISO 3183-2012 (X52 / L360 / PSL1, X56 / L390 / PSL1, X60 / L415 / PSL1, X52M / L360M / PSL2, X56M / L390M / PSL2, X60M / L415M / PSL2) ASTM A 1011/A 1011M-07 (HSLAS Grade 60 Class 1, HSLAS Grade 60 Class 2, HSLAS Grade 60 Class 1-with Cu) ASTM A 1018/A 1018M-07 (HSLAS Grade 60 Class 1, HSLAS Grade 60 Class 2) ASTM A 516-2010 (Grade 60) ASTM A572-2007 (Grade 60 Type 1) EN 10149-Part 2-1995 (S420MC (HL-2242-01), S420MC, S420MC-with Si, S420MC, S420MC-HX420LAD)</p>
8	<p>API 5L 45th Edition-2012/ISO 3183-2012 (X65 / L450 / PSL1, X65 / L450 / PSL2, X70 / L485 / PSL1, X70 / L485 / PSL2) ASTM A 1018/A 1018M-07 (HSLAS Grade 65 Class 2) ASTM A572-2007 (Grade 65 Type 1) EN 10025 Part 3 -2004 (S420N-Special (SAH540)) EN 10149-Part 2-1995 (S460MC (HL-6000-02), S460MC, S460MC-with Si, S460MC)</p>
9	<p>ASTM A 1011/A 1011M-07 (HSLAS Grade 70 Class 2, HSLAS-F Grade 80) ASTM A 1018/A 1018M-07 (HSLAS Grade 70 Class 2) EN 10025 Part 3 -2004 (S460N) EN 10149-Part 2-1995 (S500MC, S500MC-with Si, S550MC, S550MC-with Si, S600MC, S650MC, S700MC) EN 10338-2010 (HCT780X (DP 780))</p>

STANDARD HOT ROLLED COIL PRODUCTION LIMITS

Thickness (mm)	Maximum Width (mm)								
	Group-1	Group-2	Group-3	Group-4	Group-5	Group-6	Group-7	Group-8	Group-9
1.00-1.14	1000 **	1000 **							
1.15-1.19	1000	1000							
1.20-1.29	1250	1250							
1.30-1.39	1250*	1250*							
1.40-1.49	1400*	1400*	1150						
1.50-1.59	1500*	1500*	1250	1250					
1.60-1.69	1550	1550	1300	1300					
1.70-1.79	1550	1550	1350*	1350*	1000				
1.80-1.99	1650	1550	1400*	1400	1200	1000	1000		
2.00-2.09	1650	1600	1500*	1500*	1250	1000	1200*	1000*	1000*
2.10-2.19	1650	1600	1500*	1500*	1250	1000	1250	1250*	1000
2.20-2.29	1650	1600	1550	1550	1250	1100	1450	1450	1200
2.30-2.39	1650	1650	1650	1650	1450	1150	1450	1450	1200
2.40-2.49	1650	1650	1650	1650	1450	1250	1450	1450	1250
2.50-2.59	1650	1650	1650	1650	1450	1250	1450	1450	1250*
2.60-2.89	1650	1650	1650	1650	1450	1250	1450	1450	1250
2.90-2.99	1650	1650	1650	1650	1650	1450	1450	1450	1250*
3.00-3.09	1650	1650	1650	1650	1650	1450	1650	1650	1650
3.10-3.39	1650	1650	1650	1650	1650	1450	1650	1650	1650
3.40-3.89	1650	1650	1650	1650	1650	1450	1650	1650	1650
3.90-3.99	1650	1650	1650	1650	1650	1650	1650	1650	1650
4.00-4.39	1650	1650	1650	1650	1650	1650	1650	1650	1650
4.40-4.99	1650	1650	1650	1650	1650	1650	1650	1650	1650
5.00-5.79	1650	1650	1650	1650	1650	1650	1650	1650	1650
5.80-18.99	1650	1650	1650	1650	1650	1650	1650	1650	1650
19.00-26.00	1650	1650	1650	1650	1650	1650	1650	1500	1500

(*) There may be a limit difference for some steel grades in the groups with this * sign.

(**) Just for domestic market, export orders shall be discussed at the time of orders.

Notes:

For the coils with 1,5 mm and lower strip thicknesses, there may be the coil telescropy, folded and some damage at the inner and outer wraps.

**HOT ROLLED COIL PRODUCTION LIMITS FOR THE CUSTOMERS THAT
SURFACE SENSIBILITY IS IMPORTANT**

Thickness (mm)	Maximum Width (mm)								
	Group-1	Group-2	Group-3	Group-4	Group-5	Group-6	Group-7	Group-8	Group-9
1.35-1.39	1250								
1.40-1.49	1250								
1.50-1.59	1350	1350	1200						
1.60-1.69	1450	1450	1300	1200*					
1.70-1.79	1500	1500	1350*	1250*					
1.80-1.99	1500	1550	1400*	1300*					
2.00-2.09	1500	1600	1500*	1400*	1250	1000	1200	1000*	
2.10-2.19	1500	1600	1500*	1500*	1250	1000	1250	1250	
2.20-2.29	1500	1600	1550	1550	1250	1100	1450	1450	
2.30-2.39	1500	1650	1650	1650	1450	1150	1450	1450	
2.40-2.49	1500	1650	1650	1650	1450	1250	1450	1450	
2.50-2.59	1550	1650	1650	1650	1450	1250	1450	1450	
2.60-2.89	1550	1650	1650	1650	1450	1250	1450	1450	
2.90-2.99	1550	1650	1650	1650	1650	1450	1450	1450	
3.00-3.09	1650	1650	1650	1650	1650	1450	1650	1650	1650
3.10-3.39	1650	1650	1650	1650	1650	1450	1650	1650	1650
3.40-3.89	1650	1650	1650	1650	1650	1450	1650	1650	1650
3.90-3.99	1650	1650	1650	1650	1650	1650	1650	1650	1650
4.00-4.39	1650	1650	1650	1650	1650	1650	1650	1650	1650
4.40-4.99	1650	1650	1650	1650	1650	1650	1650	1650	1650
5.00-5.79	1650	1650	1650	1650	1650	1650	1650	1650	1650
5.80-18.99	1650	1650	1650	1650	1650	1650	1650	1650	1650
19.00-26.00*	1650	1650	1650	1650	1650	1650	1650	1500	1500*

(*) There may be a limit difference for some steel grades in the groups with this * sign.

Notes:

For the coils with 1,5 mm and lower strip thicknesses, there may be the coil telescopy, folded and some damage at the inner and outer wraps.

AVAILABLE SLAB LIMITS ACC. TO STRIP THICKNESS

Strip Thickness (mm)	Strip Width (mm)			
	1000-1050	1200-1270	1500	1550
	Slab Length (mm)			
1,1	8000			
1,2	8000			
1,3-1,49	11800	11800		
1,5	11800	11800		
1,8	11800	11800		
2	11800	11800		9000*
3			10000*	
4			10000*	

Notes:

- *Specified limitations, due to the legal obligations for overland transport. Longer slabs can be used for orders which will be shipped by vessels.
- For 1,3 mm and lower strip thickness, 5800 mm slabs shall be preferred.

CALCULATED COIL WEIGTHS DEPENDING ON THE SLAB LENGTHS

		Slab Length (mm)					
		5800	7300	8000	9000	10000	11800
Coil Width (mm)	900		11.1	12.2			18
	950		12.4	13.5			20
	1000	9.8	12.4	13.5			20
	1050	10.3	13.6	14.2			21
	1100	10.7	13.6	14.9			22
	1150	11.2	14.2	15.6			23
	1200	11.7	14.8	16.2			24
	1250	12.2	15.4	16.9			25
	1300	12.8		17.6		22	
	1350	13.3		18.3		22.8	
	1400	13.7		19		23.7	
	1450	14.2		19.6		24.5	
	1500	14.7		20.3		25.4	
	1550	15.2		21	23.6		
	1600	15.7		21.7	24.4		
1650	16.2		22.3				

HOT ROLLED STEEL COIL TOLERANCES

General Application

The specified values for tolerances shall not apply to the uncropped ends of the coil for a total length "l" which is calculated using the formula:

$$l (m) = \frac{90}{\text{nominal thickness (mm)}}$$

provided that the result does not exceed 20 meters. (DIN EN 10 051-1997)

TOLERANCES ON THICKNESS (DIN EN 10 051-1997)

The tolerances on thickness for continuously hot-rolled low carbon steel sheet/plate for cold forming.

Nominal Thickness (mm)	Tolerances for a nominal width (mm)		
	W ≤ 1200	1200 < W ≤ 1500	1500 < W ≤ 1650
≤ 2.00	± 0.13	± 0.14	± 0.16
> 2.00 ≤ 2.50	± 0.14	± 0.16	± 0.17
> 2.50 ≤ 3.00	± 0.15	± 0.17	± 0.18
> 3.00 ≤ 4.00	± 0.17	± 0.18	± 0.20
> 4.00 ≤ 5.00	± 0.18	± 0.20	± 0.21
> 5.00 ≤ 6.00	± 0.20	± 0.21	± 0.22
> 6.00 ≤ 8.00	± 0.22	± 0.23	± 0.23

The tolerances on thickness for steels with normal deformation resistance at elevated temperatures are given the table below. These tolerances are indicated as category A.

Nominal Thickness (mm)	Tolerances for a nominal width (mm)		
	W ≤ 1200	1200 < W ≤ 1500	1500 < W ≤ 1650
≤ 2.00	± 0.17	± 0.19	± 0.21
> 2.00 ≤ 2.50	± 0.18	± 0.21	± 0.23
> 2.50 ≤ 3.00	± 0.20	± 0.22	± 0.24
> 3.00 ≤ 4.00	± 0.22	± 0.24	± 0.26
> 4.00 ≤ 5.00	± 0.24	± 0.26	± 0.28
> 5.00 ≤ 6.00	± 0.26	± 0.28	± 0.29
> 6.00 ≤ 8.00	± 0.29	± 0.30	± 0.31
> 8.00 ≤ 10.00	± 0.32	± 0.33	± 0.34
> 10.00 ≤ 12.50	± 0.35	± 0.36	± 0.37
> 12.50 ≤ 15.00	± 0.37	± 0.38	± 0.40
> 15.00 ≤ 25.00	± 0.40	± 0.42	± 0.45

The tolerances on thickness for steels exhibiting a high deformation resistance at elevated temperatures shall be increased by the amounts specified in table below.

Category	Deformation Resistance	Increment of Thickness Tolerance
A	235 Mpa < Yield Strenght < 355 MPa	-
B	355 Mpa ≤ Yield Strenght < 420 MPa	% 15
C	420 MPa ≤ Yield Strenght < 480 MPa	% 30
D	480 Mpa ≤ Yield Strenght	% 40

Note:

The thickness shall be measured at any point situated at least 40 mm from the edges for products with mill edges. Special thickness tolerances shall be agreed at the time of enquiry and order

TOLERANCES ON WIDTH

The width shall be measured at right angles to the longitudinal axis of the product.

Nominal Width (mm)	Tolerances (mm)	
	Mill Edges	
	Lower	Upper
W ≤ 1200	0	+20
1200 < W ≤ 1500	0	+20
W > 1500	0	+25

TOLERANCES ON FLATNESS

Deviation from flatness shall be determined by measuring the deviation in distance between the product and a flat horizontal surface on which it is placed.

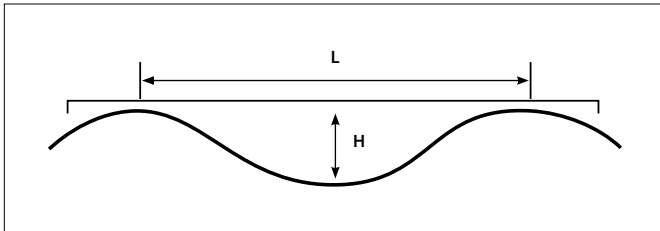

Nominal Thickness (mm)	Nominal Width (mm)	Tolerances on Flatness (mm)	Special Tolerances on Flatness (mm)
t≤2	W≤1200	18	9
	1200<W≤1500	20	10
	1500<W	25	13
2<t≤25	W≤1200	15	8
	1200<W≤1500	18	9
	1500<W	23	12

Tolerances on flatness for steels exhibiting a high deformation resistance at elevated temperatures.

For The Grades of Group B, C, D			
Category	Tolerances on Flatness (mm)		
Nominal Thickness t≤ 25 mm	Nominal Width (mm)		
	W≤1200	1200<W≤1500	W>1500
B	18	23	28
C	23	30	38
D	Shall be agreed at the time of enquiry and order.		

OUT OF SQUARENESS TOLERANCES

The out-of-squareness “u” is the orthogonal projection of a transverse edge over a longitudinal edge.

The out-of-squareness “u” measured shall not exceed 1 % of the actual width of the sheet/plate.

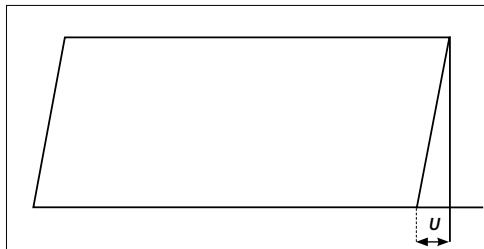

EDGE CAMBER

The Edge Camber is the maximum deviation of a longitudinal edge from a straight edge measuring base applied to it.

The camber is measured on the concave edge.

For sheet /plate the measuring base shall be the length of the product for a nominal length <5000mm.

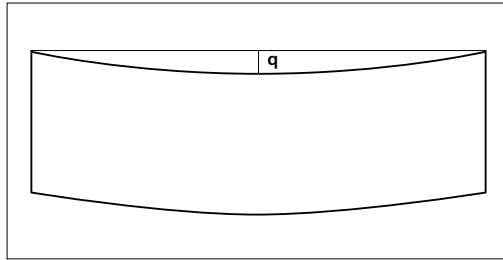

Type of Product	Dimensions		Gauge Lengths (mm)	Tolerances in "q"(mm)	
	Width (mm)	Length (mm)		Mill Edge	Trimmed Edge
Sheet - Plate	>= 600	>= 5000	5000	20	15
	>= 600	< 5000	Actual Length (L)	+ 0.005 x L	+ 0.005 x L
Coil	>= 600	-	5000	20	15

FORM OF COILS

Coils shall be tightly wound, as round as possible and edge parallel, any gradual displacement of the strip edges in one direction not exceeding 35mm for widths less than 600mm and 60mm for widths not less than 600mm for strip with mill edges.

Unless otherwise is specified at the time of order, deviations from inside diameter tolerances are as follows;

±7% for strip with mill edges.

(DIN 1016-1987)

COIL DIMENSIONS AND WEIGHTS

Tolerances on coil inside diameter and maximum values for outside diameter and coil weight are given in following table.

Description	Values and Tolerance
Inside Diameter	762 +0/-50
Outside Diameter	Max. 2100 mm
Coil Weight	Max. 39 tonnes

FLOOR PLATES (TEARDROP PATTERN) PRODUCTION LIMITS AND TOLERANCES

Floor plates produce according to ASTM A786/A786M(2009) with the Pattern No: 4.
Production limits are as in follows;

Thick-ness (mm)	Maximum Width (mm)								
	Group1	Group2	Group3	Group4	Group5	Group6	Group7	Group8	Group9
2.0-2.99		1250							
3.0-3.99		1550							
4.0-4.99		1550							
5.0-5.99		1550							
6.0-12.0		1550							

Notes:

Minimum order width is 800 mm.

Other grades shall be discussed at the time of orders.

Minimum mill campaign shall be 2000 m tonnes.

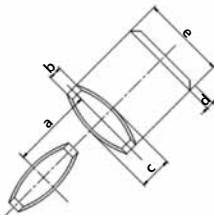
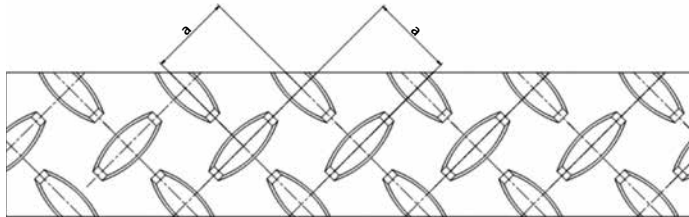

	Dimension
a	~ 30 mm
b	4 +/- 0.5 mm
c	8.5 +/- 1 mm
d	1-2 mm*
e	30 +/- 2 mm

* Except the core thickness between 4 - 2.5 mm for which the height of patern (d) may vary 0.7 mm to 2 mm and core thickness of less than 2.5 mm for which the height of patern (d) may vary 0.5 mm to 2 mm.





LONG STEEL PRODUCTS

CHEMICAL &
MECHANICAL PROPERTIES

Billet

Size :	130 x 130 mm. 150 x 150 mm. 200 x 200 mm.
Length :	6 - 16 m.

Reinforcing Steel Bar

Diameter :	8 - 40 mm
Length :	6 - 18 m

Threaded Bar (Helical Rod)

Diameter :	16 - 28 mm
Length :	6 - 18 m

BILLET FOR CARBON STEEL QUALITIES

Chemical Composition (%)

Qualities	Standard	C	Mn	Si	P	S	Cr
		max.	max.	max.	max.	max.	max.
SAE 1005	SAE J 403	0.06max.	0.35max.	0.03-0.10	0.030	0.050	0.20
SAE 1006	SAE J 403	0.08max.	0.40max.	0.03-0.10	0.030	0.050	0.20
SAE 1008	SAE J 403	0.06-0.10	0.30-0.50	0.05-0.15	0.030	0.050	0.20
SAE 1010	SAE J 403	0.08-0.13	0.30-0.60	0.05-0.15	0.030	0.050	0.20
SAE 1012	SAE J 403	0.10-0.15	0.30-0.60	0.05-0.15	0.030	0.050	0.20
SAE 1015	SAE J 403	0.13-0.18	0.30-0.60	0.05-0.15	0.030	0.050	0.20
SAE 1018	SAE J 403	0.15-0.20	0.60-0.90	0.15-0.35	0.030	0.050	0.20
SAE 1020	SAE J 403	0.18-0.23	0.30-0.60	0.15-0.35	0.030	0.050	0.20
SAE 1030	SAE J 403	0.28-0.34	0.60-0.90	0.15-0.35	0.030	0.050	0.20
SAE 1035	SAE J 403	0.32-0.38	0.60-0.90	0.15-0.35	0.030	0.050	0.20
SAE 1040	SAE J 403	0.37-0.44	0.60-0.90	0.15-0.35	0.030	0.050	0.20
SAE 1045	SAE J 403	0.43-0.50	0.60-0.90	0.15-0.35	0.030	0.050	0.20
SAE 1050	SAE J 403	0.48-0.55	0.60-0.90	0.15-0.35	0.030	0.050	0.20
SAE 1055	SAE J 403	0.50-0.60	0.60-0.90	0.15-0.35	0.030	0.050	0.20
SAE 1060	SAE J 403	0.55-0.65	0.60-0.90	0.15-0.35	0.030	0.050	0.20

BILLET FOR REINFORCING STEEL BARS

Chemical Composition (%)

Qualities	Standard	C	Mn	Si	P	S	Cr
		max.	max.	max.	max.	max.	max.
CA 50	ABNT NBR 7480 : 2017	0.14-0.22	0.60-1.20	0.10-0.40	0.050	0.050	0.30
A 500C	ACHM 7-93	0.14-0.22	0.60-1.20	0.10-0.40	0.050	0.050	0.30
GR 40	ASTM A 615	0.20-0.34	0.60-1.10	0.10-0.40	0.060	0.050	0.30
GR 60	ASTM A 615	0.30-0.44	0.90-1.40	0.10-0.40	0.060	0.050	0.30
GR 75	ASTM A 615	0.30-0.44	0.90-1.40	0.10-0.40	0.060	0.050	0.30
GR 60	ASTM A 706	0.20-0.30	0.70-1.30	0.10-0.40	0.035	0.045	0.30
B 500B	BDS 9252 : 2007	0.14-0.22	0.60-1.20	0.10-0.40	0.050	0.050	0.30
GR 460 B	BS 4449:1997	0.14-0.25	0.60-1.20	0.10-0.40	0.050	0.050	0.30
B 500 B	BS 4449:2005	0.14-0.22	0.60-1.30	0.10-0.40	0.050	0.050	0.30
B 500 C	BS 4449:2005	0.14-0.22	0.60-1.30	0.10-0.40	0.050	0.050	0.30
GR 400R	CAN/CSA.G30.18-09	0.18-0.38	0.90-1.30	0.10-0.40	0.050	0.050	0.30
GR 400W	CAN/CSA.G30.18-09	0.18-0.30	0.60-1.30	0.10-0.40	0.035	0.045	0.30
GR 500R	CAN/CSA.G30.18-09	0.18-0.38	0.60-1.30	0.10-0.40	0.050	0.050	0.30
GR 500W	CAN/CSA.G30.18-09	0.26-0.30	0.70-1.30	0.10-0.40	0.035	0.045	0.30
St 50	DIN 17100	0.24-0.33	0.60-0.90	0.10-0.40	0.050	0.050	0.30
St 60	DIN 17100	0.34-0.43	0.60-0.90	0.10-0.40	0.050	0.050	0.30
St37-2	DIN 17100	0.05-0.19	0.30-0.6	0.05-0.30	0.050	0.050	0.30
B 500 B	DIN 488: 2009	0.14-0.22	0.60-1.20	0.10-0.40	0.050	0.050	0.30
B 450 C	DM 14.01.2008	0.14-0.22	0.60-1.20	0.10-0.40	0.050	0.050	0.30
A 400 NR	E 449 : 2010	0.14-0.22	0.60-1.20	0.10-0.40	0.050	0.050	0.30
A 500 NR	E 450 : 2010	0.14-0.22	0.60-1.20	0.10-0.40	0.050	0.050	0.30
3SP	GOST 380	0.14-0.22	0.40-0.65	0.15-0.30	0.040	0.050	0.30
5SP	GOST 380	0.28-0.37	0.50-0.80	0.15-0.30	0.040	0.050	0.30
B 500 BWR	IS 6935-2 : 2007	0.14-0.22	0.60-1.20	0.10-0.40	0.050	0.050	0.30
S 400	IS 4466-3 : 2013	0.14-0.38	0.60-1.30	0.10-0.40	0.050	0.050	0.30
S 400 W	IS 4466-3 : 2013	0.18-0.24	0.70-1.40	0.10-0.40	0.050	0.050	0.30
S 500 W-C	IS 4466-3 : 2013	0.24	1.80	0.55	0.050	0.050	-
GR 300	JS 33: 2013	0.14-0.22	0.60-1.00	0.10-0.40	0.050	0.050	0.30
GR 400	JS 33: 2013	0.14-0.22	0.60-1.00	0.10-0.40	0.050	0.050	0.30
B 500 B	MS 146 : 2006	0.14-0.22	0.60-1.20	0.10-0.40	0.050	0.050	0.30
A 630- 420H	NCh 206 : 2006	0.30-0.43	0.70-1.40	0.10-0.40	0.050	0.050	0.30
A 440- 280H	NCh 206 : 2006	0.20-0.30	0.60-0.90	0.10-0.40	0.050	0.050	0.30
B 500 B	NEN 6008:2008	0.14-0.22	0.60-1.20	0.10-0.40	0.050	0.050	0.30
FEE 400	NF A 35-016:1986	0.14-0.22	0.60-1.20	0.10-0.40	0.050	0.050	0.30
FEE 500	NF A 35-016:1996	0.14-0.22	0.60-1.20	0.10-0.40	0.050	0.050	0.30
B 500 B	NF A 35- 080-1:2013	0.14-0.22	0.60-1.20	0.10-0.40	0.050	0.050	0.30
GR 60	NTC 2289:2012	0.26-0.30	0.60-1.20	0.10-0.40	0.035	0.045	0.30
OB 37	SR 438-1:2012	0.18-0.23	0.40-0.75	0.10-0.40	0.045	0.045	0.30
PC 52	SR 438-1:2012	0.18-0.22	0.60-1.20	0.10-0.55	0.045	0.045	0.30
B 420 B	TS 708 : 2016	0.14-0.22	0.60-1.20	0.10-0.40	0.050	0.050	0.30
B 420C	TS 708 : 2016	0.14-0.22	0.60-1.20	0.10-0.40	0.050	0.050	0.30
B 500 B	TS 708 : 2016	0.14-0.22	0.60-1.20	0.10-0.40	0.050	0.050	0.30
B 500 C	TS 708 : 2016	0.14-0.22	0.60-1.20	0.10-0.40	0.050	0.050	0.30
S 420	TS 708 : 2016	0.14- 0.45	0.60-1.20	0.10-0.40	0.050	0.050	0.30
GR 40	INTE 06-09-01	0.20-0.30	0.60-1.10	0.10-0.40	0.060	0.050	0.30
GR 60	INTE 06-09-01	0.30-0.44	0.90-1.40	0.10-0.40	0.060	0.050	0.30
GR 60	INTE 06-09-02	0.20-0.30	0.70-1.30	0.10-0.40	0.035	0.045	0.30

Ni	Cu	Mo	V	N	Ceq
max.	max.	max.	max.	max.	max.
0.30	0.50	0.050	0.010	0.012	0.50
0.30	0.50	0.050	0.010	0.012	0.50
0.30	0.50	0.050	0.010		
0.30	0.50	0.050	0.010		
0.30	0.50	0.050	0.060		
0.30	0.50	0.050	0.010		0.55
0.30	0.80	0.050	0.010	0.012	0.50
0.30	0.50	0.050	0.010	0.012	0.51
0.30	0.80	0.050	0.03	0.012	0.50
0.30	0.80	0.050	0.030	0.012	0.50
0.30	0.50	0.050	0.030		
0.30	0.50	0.050	0.010		0.55
0.30	0.50	0.050	0.010		
0.30	0.50	0.050	0.010		0.55
0.30	0.50	0.050	0.010		
0.30	0.50	0.050	0.010		
0.30	0.50	0.050	0.010	0.012	0.50
0.30	0.50	0.050	0.010	0.012	0.50
0.30	0.50	0.050	0.010	0.012	0.50
0.30	0.50	0.050	0.010	0.012	0.50
0.30	0.30	0.050	0.010	0.010	
0.30	0.30	0.050	0.010	0.010	
0.30	0.50	0.050	0.010	0.012	0.50
0.30	0.50	0.050	0.010		0.60
0.30	0.50	0.050	0.010		0.55
-	-	-	-	-	0.55
0.30	0.50	0.050	0.010		0.40
0.30	0.50	0.050	0.010		
0.30	0.50	0.050	0.010	0.012	0.50
0.30	0.50	0.050	0.010		
0.30	0.50	0.050	0.010		
0.30	0.50	0.050	0.010		0.50
0.30	0.50	0.050	0.010	0.012	0.50
0.30	0.50	0.050	0.010	0.012	0.50
0.30	0.50	0.050	0.010	0.012	0.50
0.30	0.50	0.050	0.010		0.55
0.30	0.50	0.050	0.010		
0.30	0.50	0.050	0.010		0.50
0.30	0.80	0.050	0.010	0.012	0.50
0.30	0.80	0.050	0.010	0.012	0.50
0.30	0.80	0.050	0.010	0.012	0.50
0.30	0.80	0.050	0.010	0.012	0.50
0.30	0.50	0.050	0.010		
0.30	0.50	0.050	0.010		
0.30	0.50	0.050	0.010		
0.30	0.50	0.050	0.040		0.55

REINFORCING STEEL BAR QUALITIES - 1													
Chemical Composition (%)													
Qualities	Standard	C	Mn	Si	P	S	Cr	Ni	Cu	Mo	V	N	Ceq
		max.	max.	max.	max.	max.	max.	max.	max.	max.	max.	max.	max.
A 400 NR	E 449 : 2010	0,22			0,050	0,050			0,80			0,012	0,50
A 440- 280H	NCh 204:2006	-	-	-	-	-	-	-	-	-	-	-	-
A 500 NR	E 450 : 2010	0,22			0,050	0,050			0,80			0,012	0,50
A 500C	ACHM 7-93	0,22	1,60	0,90	0,050	0,050						0,012	0,50
A 630- 420H	NCh 204:2006	-	-	-	-	-	-	-	-	-	-	-	-
B 420 B	TS 708 : 2016	0,22			0,050	0,050			0,80			0,012	0,50
B 420C	TS 708 : 2016	0,22			0,050	0,050			0,80			0,012	0,50
B 450 C	DM. 14/01/2008	0,22			0,050	0,050			0,80			0,012	0,50
B 500 B	BS 4449:2005	0,22			0,050	0,050			0,80			0,012	0,50
B 500 B	DIN 488:2009	0,22			0,050	0,050			0,60			0,012	0,50
B 500 B	NEN 6008:2008	0,22			0,050	0,050			0,80			0,012	0,50
B 500 B	NF A35-080-1:2013	0,22			0,050	0,050			0,80			0,012	0,50
B 500 B	TS 708 : 2016	0,22			0,050	0,050			0,80			0,012	0,50
B 500 BWR	IS 6935-2:2007	0,22	1,60	0,60	0,050	0,050						0,012	0,50
B 500 C	BS 4449:2005	0,22			0,050	0,050			0,80			0,012	0,50
B 500 C	TS 708 : 2016	0,22			0,050	0,050			0,80			0,012	0,50
B 500B	BDS 9252:2007	0,22			0,050	0,050			0,80			0,012	0,50
B 500B	NFA 35-080:2013	0,22			0,050	0,050						0,012	0,50
CA 50	ABNT NBR 7480	-	-	-	-	-	-	-	-	-	-	-	-
FEE 400	NFA 35-016:1986	0,22			0,050	0,050						0,012	0,50

REINFORCING STEEL BAR QUALITIES - 1

Mechanical Properties (%)

Qualities	Standard	Yield Strength (Re) N/mm ² (min.)	Tensile Strength (Rm) N/mm ² (min.)	Elongation % (min.)	(Agt) % (min.)	Rm/Re (min.)	Re, act /Re, nom (max.)
A 400 NR	E 449 : 2010	400			5	1,08	
A 440- 280H	NCh 204 : 2006	280	440	16		1,25	
A 500 NR	E 450 : 2010	500			5	1,08	
A 500C	ACHM 7-93	500	600	14			
A 630- 420H	NCh 204 : 2006	420 - (Max = 580)	630	8		1,25	
B 420 B	TS 708 : 2016	420		12	5	1,08	
B 420C	TS 708 : 2016	420		12	7,5	1,15 (Max=1,35)	1,30
B 450 C	DM. 14/01/2008	450	540		7,50	1,15 (Max=1,35)	1,25
B 500 B	BS 4449:2005	500 (Max=650)			5,00	1,08	
B 500 B	DIN 488 : 2009	500			5	1,08	1,30
B 500 BWR	IS 6935-2:2007	500		14	5	1,08	
B 500 C	BS 4449:2005	500 (Max=650)			7,5	1,15 (Max=1,35)	
B 500B	BDS 9252:2007	500	550		5		1,25
B 500B	MS 146 :2006	500		12		1,05	
B 500B	NEN 6008 : 2008	500			5	1,08	
B 500B	NF A35-080-1:2013	500					
B 500B	NFA 35-080:2015	500			5	1,08	
B 500B	TS 708 : 2016	500		12	5	1,08	
B 500C	TS 708 : 2016	500		12	7,5	1,15 (Max=1,35)	1,30
CA 50	ABNT NBR 7480	500		8	5	1,08	
FEE 400	NFA 35-016:1986	400	440	14	5	1,05	

REINFORCING STEEL BAR QUALITIES - 2													
Chemical Composition (%)													
Qualities	Standard	C	Mn	Si	P	S	Cr	Ni	Cu	Mo	V	N	Ceq
		max.	max.	max.	max.	max.	max.	max.	max.	max.	max.	max.	max.
FEE 500	NFA 35-016:1996	0,22			0,050	0,050						0,012	0,50
GR 300	JS 33 : 2013				0,050								0,40
GR 40	ASTM A 615				0,060								
GR 40	INTE 06-09-01				0,060								
GR 400	JS 33 : 2013				0,050								
GR 400R	CAN/CSA G30.18-09				0,050								
GR 400W	CAN/CSA G30.18-09	0,30	1,60	0,50	0,035	0,045							0,55
GR 460 B	BS 4449:1997	0,25			0,050	0,050						0,012	0,51
GR 500 B	MS 146 : 2006	0,30			0,050	0,050						0,012	0,51
GR 500R	CAN/CSA G30.18-09				0,050								
GR 500W	CAN/CSA G30.18-09	0,30	1,60	0,50	0,035	0,045							0,55
GR 60	ASTM A 615				0,060								
GR 60	ASTM A 706	0,30	1,50	0,50	0,035	0,045							0,55
GR 60	NTC 2289:2012	0,30	1,50	0,50	0,035	0,045							0,55
GR 60	INTE 06-09-01				0,060								
GR 60	INTE 06-09-02	0,30	1,50	0,50	0,035	0,045							0,55
GR 75	ASTM A 615				0,060								
OB 37	SR 438-1:2012	0,23	0,75	0,07	0,045	0,045	0,30	0,30					
PC 52	SR 438-1:2012	0,22	1,60	0,55	0,045	0,045	0,30	0,30	0,50				0,50
S 400	IS 4466-3:2013	0,38			0,050	0,050							0,60
S 400 W	IS 4466-3:2013	0,24			0,050	0,050							0,55
S 500 W-C	IS 4466-3:2013	0,24	1,80	0,55	0,050	0,050	-	-	-	-	-	-	0,55
S 420	TS 708 : 2016	0,45			0,050	0,050							

REINFORCING STEEL BAR QUALITIES - 2

Mechanical Properties (%)

Qualities	Standard	Yield Strength (Re) N/mm ² (min.)	Tensile Strength (Rm) N/mm ² (min.)	Elongation % (min.)	(Agt) % (min.)	Rm/Re (min.)	Re, act/Re, nom (max.)
FEE 500	NFA 35-016:1996	500			5	1,08	
GR 40	INTE 06-09-01	275 - (Max=398)	412	11 - 12			
GR 60	INTE 06-09-01	412 - (Max=535)	618	7 - 9			
GR 60	INTE 06-09-02	420 - (Max=540)	550	10 - 14		1,25	
GR 60	NTC 2289-2012	420 - (Max=540)	550	10 - 14		1,25	
GR 300	JS 33 : 2013	300 - (Max=425)		10 - 12		1,25	
GR 40	ASTM A 615	280	420	10 - 12			
GR 400	JS 33 : 2013	400 - (Max=525)		7 - 9		1,25	
GR 400R	CAN/CSA G30.18-09	400	540	7 - 10		1,15	
GR 400W	CAN/CSA G30.18-09	400 - (Max=525)	540	12 - 13		1,15	
GR 460 B	BS 4449:1997	460		14	5	1,08	
GR 500R	CAN/CSA G30.18-09	500	675	6 - 9		1,15	
GR 500W	CAN/CSA G30.18-09	500 - (Max=625)	625	10 - 12		1,15	
GR 60	ASTM A 615	420	620	7 - 9			
GR 60	ASTM A 706	420 (Max= 540)	550	10 - 14		1,25	
GR 75	ASTM A 615	520	690	6 - 7			
OB 37	SR 438-1:2012	6mm≤d≤12mm=255 14mm≤d≤40mm=235	360	25			
PC 52	SR 438-1:2012	8mm≤d≤14mm=355 16mm≤d≤28mm=345 32mm≤d≤40mm=335	510	20			
S 400	IS 4466-3 : 2013	400 - (Max=520)		12	8	1,25	
S 400 W	IS 4466-3 : 2013	400 - (Max=520)		12	8	1,25	
S 500 W-C	IS 4466-3 : 2013	500 - (Max=650)		11	7,5	1,15 -(Max=1,35)	
S 420	TS 708 : 2016	420 - (Max=546)	500	10		1,15	1,30



HELICAL RODS QUALITIES

Chemical Composition (%)

Qualities	Standard	C	Mn	Si	P	S	Cr	Ni	Cu	Mo	V	N	Ceq
		max.	max.	max.	max.	max.	max.	max.	max.	max.	max.	max.	max.
A 630-420H	NCh 204 : 2006	0.45 max	1,60	0.30 max.	0.050	0.050	0.30	0.30	0.50	0.050	0.030		
A 440-280H	NCh 204 : 2006	0.33 max	1,00	0.30 max.	0.050	0.050	0.30	0.30	0.50	0.050			
St 450/700	DIN Material No 1.1165	0.27-0.34	1,50	0.15-0.40	0.035	0.035	0.30	0.30	0.50	0.050	0.050		

* Different chemical requirements and qualities shall be discussed.

Mechanical Properties (%)

Qualities	Standard	Yield Strength (Re) N/mm ² (min.)	Tensile Strength (Rm) N/mm ² (min.)	Elongation % (min.)	(Agt) % (min.)	Rm/Re (min.)	Re, act/Re, nom (max.)
A 630-420H	NCh 204 : 2006	420 - (Max = 580)	630	8		1,25	
A 440-280H	NCh 204 : 2006	280	440	16		1,25	
St 450/700	DIN Material No 1.1165	450	700	15			

* Different requirements shall be discussed.

COLAKOĞLU
DÖKÜM A.Ş.



IA01351K026

DÖKÜM NO : IA01351

BOY(MM) : 12000.0

Colakoglu Metalurji A.Ş.
Düvazlar Organize
Kisim No: 6 41460 Çarşamba / Kocaeli

COLAKOĞLU
DÖKÜM A.Ş.



IA01351K026

DÖKÜM NO : IA01351

BOY(MM) : 12000.0

Colakoglu Metalurji A.Ş.
Düvazlar Organize
Kisim No: 6 41460 Çarşamba / Kocaeli

COLAKOĞLU
DÖKÜM A.Ş.



IA01351K025

DÖKÜM NO : IA01351

BOY(MM) : 12000.0



Colakoglu Metalurji A.Ş.
Düvazlar Organize
Kisim No: 6 41460 Çarşamba / Kocaeli

LONG STEEL PRODUCTS

TOLERANCES



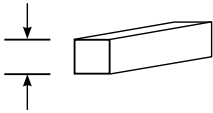
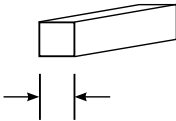
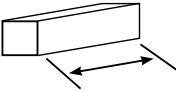
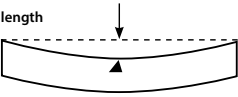

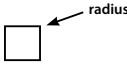
BILLET TOLERANCES		
	Tolerances	
Thickness	130 mm : ± 3 mm 150 mm : ± 5 mm	
Width	130 mm : ± 3 mm 150 mm : ± 5 mm	
Length	± 100 mm	
Straightness	(≤ 10 mm/m)	
Rhomboidity	$\leq 6\%$ mm	
Twist	$\leq 1^\circ$ / m	
Corner Radius	130 mm : ≤ 8 mm 150 mm : ≤ 10 mm	

**PACKAGING &
LABELLING**



FLAT STEEL PRODUCTS

SLAB

Labelling

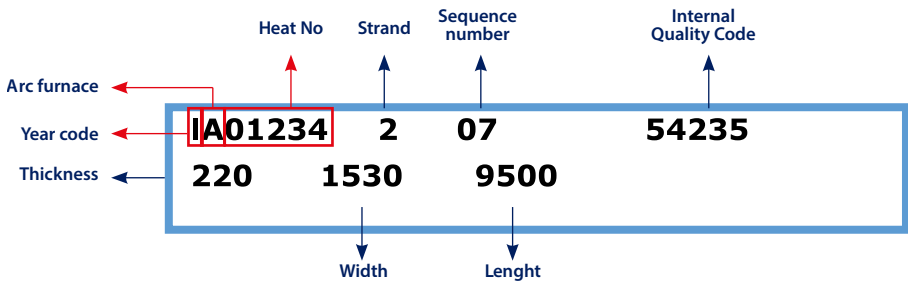



FLAT STEEL PRODUCTS

HOT ROLLED FLAT STEEL COIL

HOT ROLLED CHEQUERED

Packaging

- 3 circumferential straps + 3 radial straps

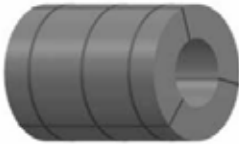

Labelling

- Overseas Shipment
3 circumferential straps + 4 radial straps

Colakoglu logo		ÇOLAKOĞLU METALURJİ A.Ş.*		CE Certificate logo
Coil number	COIL NO: I016401000		0 620 CPR - 58521	CE Certificate number
Product description	PRODUCT: HRC			
Quality	QUALITY: S235JR			
Standard	STANDARD: DIN EN 10025-2			
Slab number	HEAT NO: IA00659101			Number of slabs produced from the heat
Coil thickness	THICKNESS(MM) : 4.00			Strand number of the heat
Coil width	WIDTH(MM) : 1000.0			
Coil weight	WEIGHT(KG) : 20.500			
	Made in Turkey		DOP:CM 001	Performance declaration number

LONG STEEL PRODUCTS

BILLET**Labelling**



LONG STEEL PRODUCTS
**REINFORCING STEEL BAR /
 THREADED BAR (HELICAL ROD)**

Labelling



- According to our customers request, Reinforcing Steel Bar / Threaded Bar labels are arranged .

NOTES

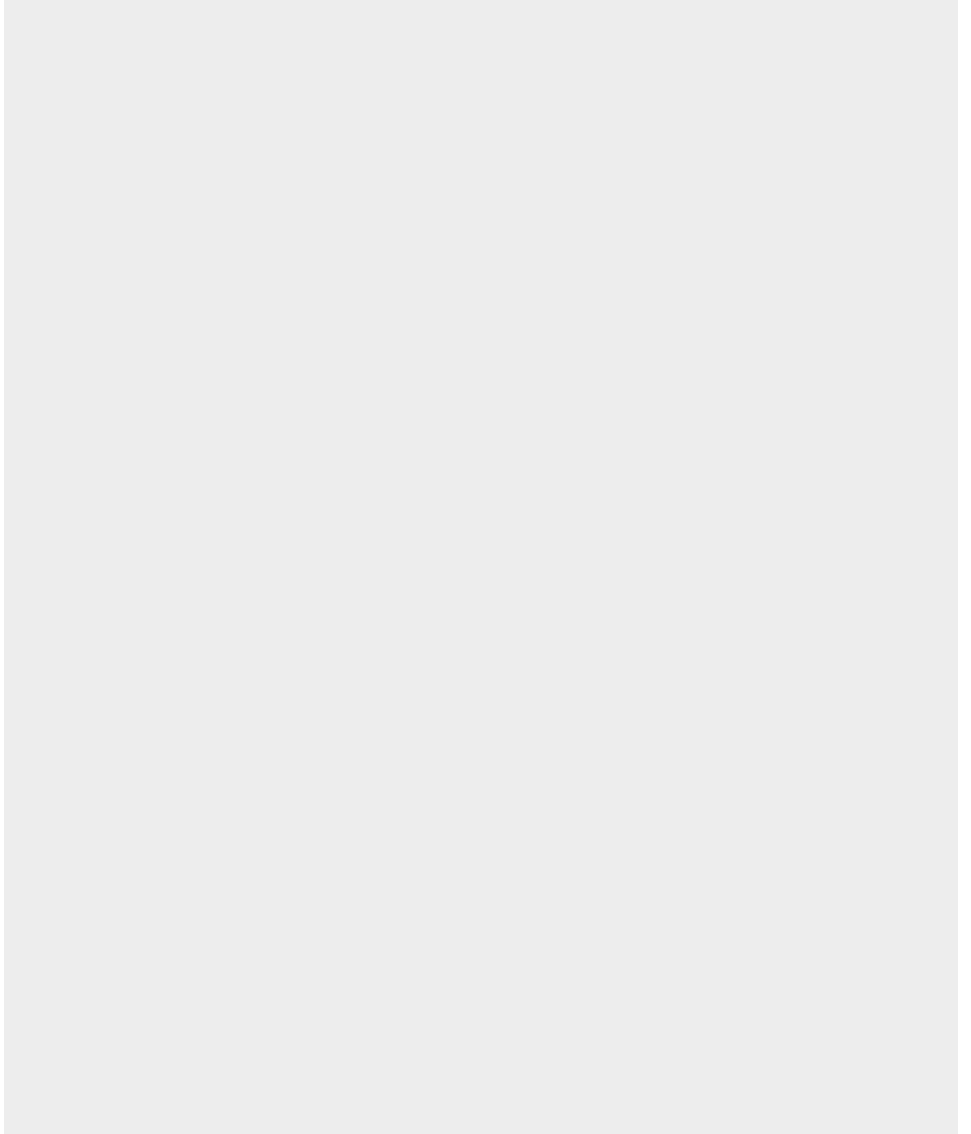

NOTES

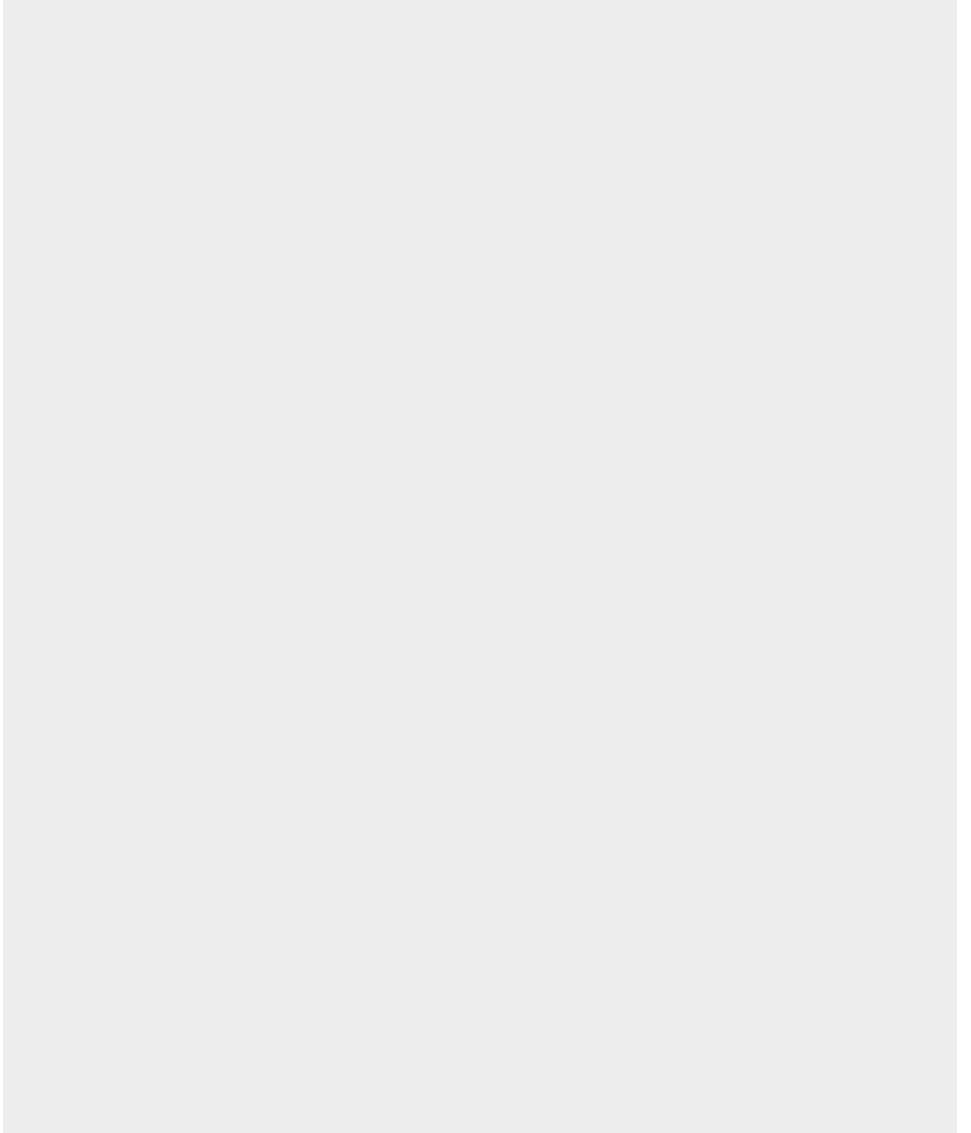

NOTES

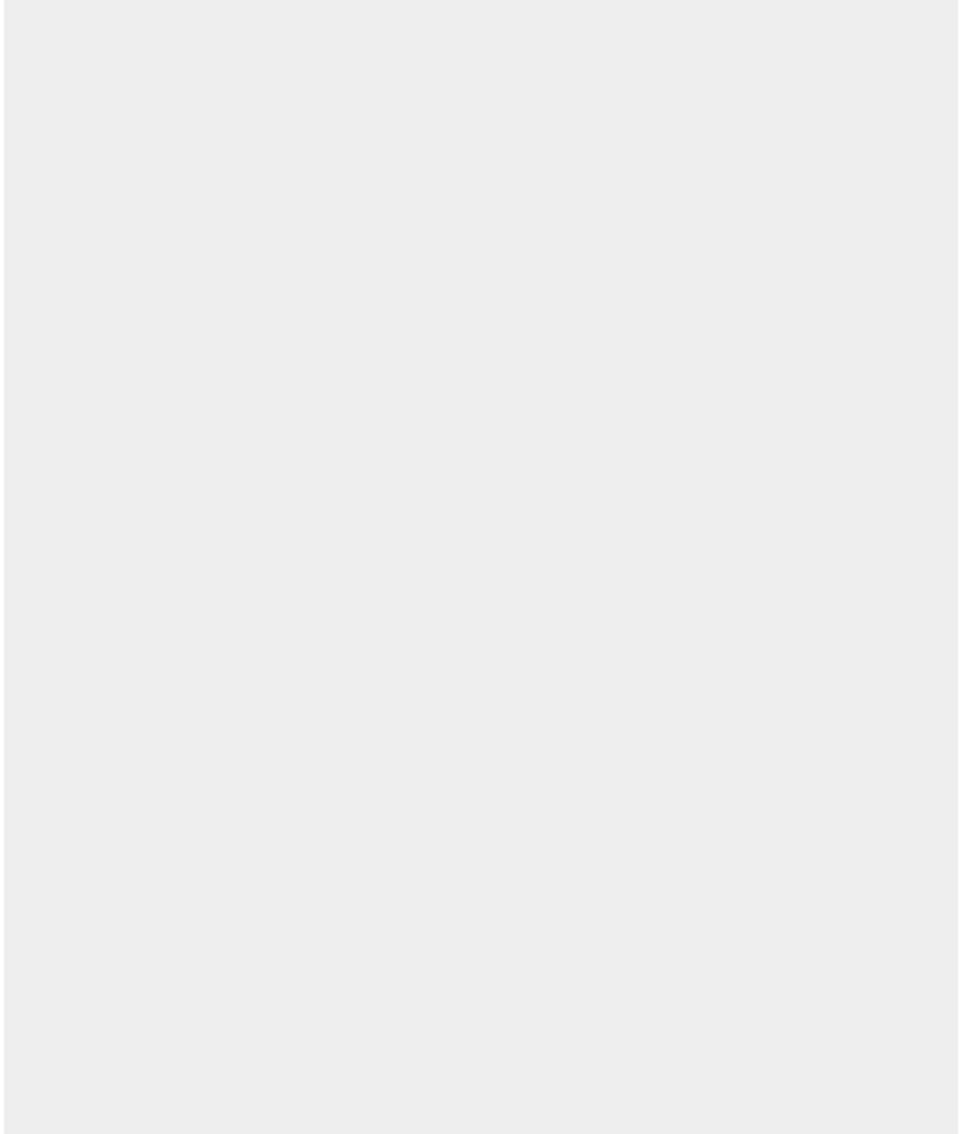

Çolakođlu Metalurji A.Ş.

Headquarter

Rüzgarlıbahçe Mahallesi Kavak Sokak No:16 Kat:5

34805 Kavacık-Beykoz / İstanbul,TURKEY

T: +90 (216) 681 2600 • F: +90 (216) 537 1401

Production Facility

Dilovası Organize Sanayi Bölgesi

1. Kısım Göksu Caddesi No:6 41455 Dilovası-Kocaeli,TURKEY

T: +90 (262) 676 75 00 • F: +90 (262) 754 84 20

Production Facility (Reinforcing Bar)

Dilovası Organize Sanayi Bölgesi, 5.Kısım D 5007 Sokak

Yunus Emre Caddesi No:21 Dilovası-Kocaeli,TURKEY

T: +90 (262) 676 75 00 • F: +90 (262) 754 84 20

www.colakoglu.com.tr

444 26 27 (444 CMAS)

 <https://www.facebook.com/colakoglumetalurji.as>

 <https://tr.linkedin.com/company/colakoglu-metalurji-a-s>

